

CUSTOMER :

NO : 080315-01

# S P E C I F I C A T I O N

## APPLICATION FOR APPROVAL OF

ITEM : RADIAL INDUCTOR  
DESCRIPTION : DR 4 × 5.5mm  
CODE NO : DR1)10uH(TAPING & BULK)  
MODEL NO :

This space is used for customer's approval

DATE : 2008. 05. 10.

DRAWN BY Y. H. JEON	DATE 2008. 5. 10.
CHECKED BY	DATE.
APPROVED BY J. G. KIM	DATE 2008. 5. 10.

CUSTOMER :

SPECIFICATION		SHEET NO.	1 OF 7			
		D A T E	2008. 5. 10.			
PART NAME	Radial Inductor	MODEL NAME				
PART NO.	DR1-10uH-T.B	DESCRIPTION	DR 4 × 5.5mm			
<p>1. GENERAL SPECIFICATION</p> <p>1) SCOPE This specification applies to part number <u>10uH</u> <b>PEAKING COIL</b> for use in electronic appliances which is supplied for</p> <p>2. MECHANICAL CHARACTERISTIC <b>PEAKING COIL</b> shall conform in size, dimension, and other mechanical properties, to the part drawing attached here to.</p> <p>1) Marking : <b>PEAKING COIL</b> shall be permanently and legibly marked with the part number on the specification position.</p> <p>2) Terminal strength : Terminal shall withstand for <u>30</u> seconds without breakdown on losing when a static load of <u>2</u> Kg is applied in the drawing direction to the terminal at the point where the external load.</p> <p>3. ENVIRONMENTAL &amp; LIFE CHARACTERISTIC</p> <p>1) Temperature rise : Temperature rise of the each winding and core shall be less than <u>ambient + 65°C</u> , when the <b>PEAKING COIL</b> continuously operated at full load(test load) until constant temperature is attained.</p> <p>2) Heat-resistance : Immediately after <b>PEAKING COIL</b> being placed in room for <u>96</u> Hours maintained AT <u>105°C ± 2°C</u> ambient temperature, the <b>PEAKING COIL</b> shall conform with the above part paragraph (4) and also insulation resistance shall be more than <u>100</u> MΩ.</p> <p>3) Moisture resistance : Immediately after <b>PEAKING COIL</b> being placed in room for <u>120</u> Hours in such humidity chamber this is maintained at <u>90 - 95%</u> relative humidity and <u>55°C ± 2°C</u> temperature and wiped a drop of water, <b>PEAKING COIL</b> shall conform with the above paragraph(4) and also insulation shall be the <u>10</u> MΩ.</p> <p>4) Safety consideration : <b>PEAKING COIL</b> shall meet all the requirements subject to <u>IEC-950</u> standards for safety of information technology equipment including electrical business equipment.</p> <p>5) Solderability : Dip pads in RMA flux, 96.5/0.5/3 solder (Sn/Cu/Ag)at 260°C for 5±2 seconds</p>						
NO	REVISION	DATE	CHECK	DRAWN	CHECKED	APPROVED
1						
2						
3						
4						

CUSTOMER :

<b>SPECIFICATION</b>		SHEET NO.	2 OF 7
		D A T E	2008. 5. 10.
PART NAME	Radial Inductor	MODEL NAME	
PART NO.	DR1-10uH-T.B	DESCRIPTION	DR 4 × 5.5mm

4-2. APPEARANCE & DIMENSION (UNIT:m/m)

Marking : 100K or 100

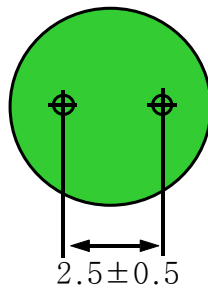
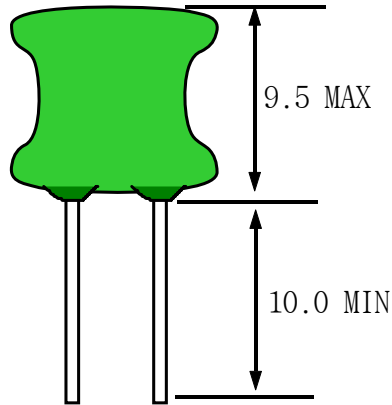
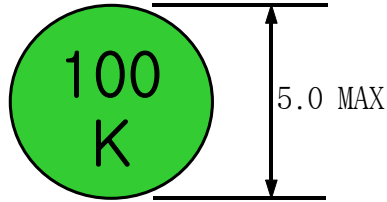

CUSTOMER :

4. APPEARANCE & DIMENSION (UNIT:m/m)		SHEET NO.	3 OF 7
<b>SPECIFICATION</b>		D A T E	2008. 5. 10.
		MODEL NAME	
PART NAME	Radial Inductor	DESCRIPTION	DR 4 × 5.5mm
PART NO.	DR1-10uH-T.B		

1. APPEARANCE & DIMENSION (UNIT:m/m)

MARKING: 100K or 100

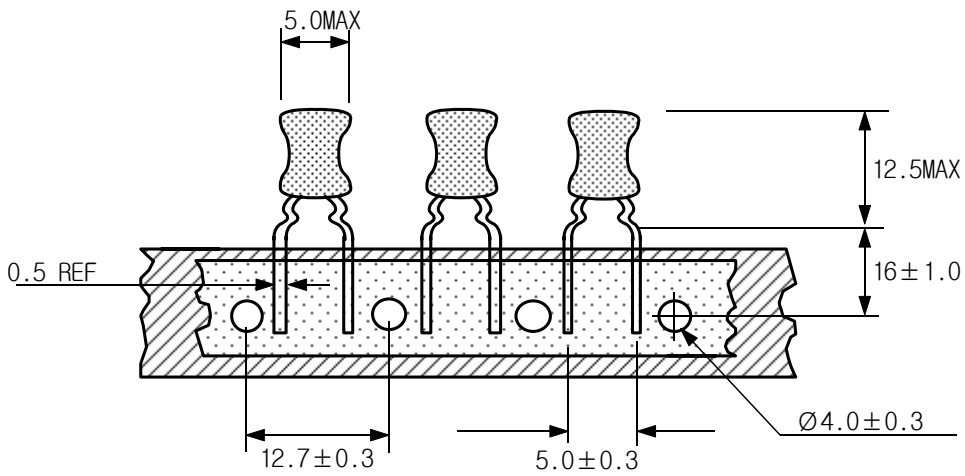
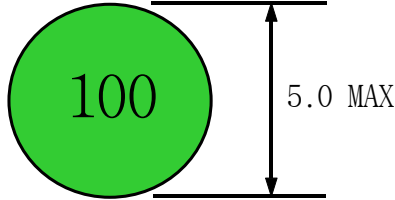

NO	REVISION	DATE	CHECK	DRAWN	CHECKED	APPROVED
1						
2						
3						
4						



CUSTOMER :

<b>SPECIFICATION</b>		SHEET NO.	4 OF 7
		D A T E	2008. 5. 10.
PART NAME	Radial Inductor	MODEL NAME	
PART NO.	DR1-10uH-T.B	DESCRIPTION	DR 4 × 5.5mm

5. WINDING SPEC

START & FINISH	TYPE OF WIRE	T U R N S	WINDING METHODE
	UEW 0.23Ø	<u>24.5</u> t REF	SOLENOID WINDING [C. C. W]

6. ELECTRICAL CHARACTERISTIC

NO	I T E M	MESURE	SPECIFICATION	REMARKS
1	INDUCTANCE	START & FINISH	<u>10</u> [uH] MIN	LCR-METER HP-4284A at 1KHz 1Vrms
2	DC RESISTANCE	START & FINISH	<u>0.2</u> [Ω] MAX	WHEATSTONE BRIDGE TYPE 2755 TYPE 3220
3	LAYER SHORT	START & FINISH	AC <u>1</u> [KV] , FREQUENCY <u>60</u> [Hz]	
4	DIELECTRIC WITHSTANDING TEST	COIL & CORE	AC <u>1</u> [KV] , FREQUANCY <u>60</u> [Hz] , <u>1</u> MINUTES, CUT OFF CURENT <u>5</u> [mA]	NO BREAKDOWN
5	INSULATION RESISTANCE	COIL & CORE	DC <u>500</u> [V] , <u>100</u> [MΩ] MIN	

NO	REVISION	DATE	CHECK	DRAWN	CHECKED	APPROVED
1						
2						
3						
4						

CUSTOMER :

<h1>SPECIFICATION</h1>		SHEET NO.	5 OF 7
		D A T E	2008. 5. 10.
PART NAME	Radial Inductor	MODEL NAME	
PART NO.	DR1-10uH-T.B	DESCRIPTION	DR 4 × 5.5mm

7. SCHEMATIC DIAGRAM

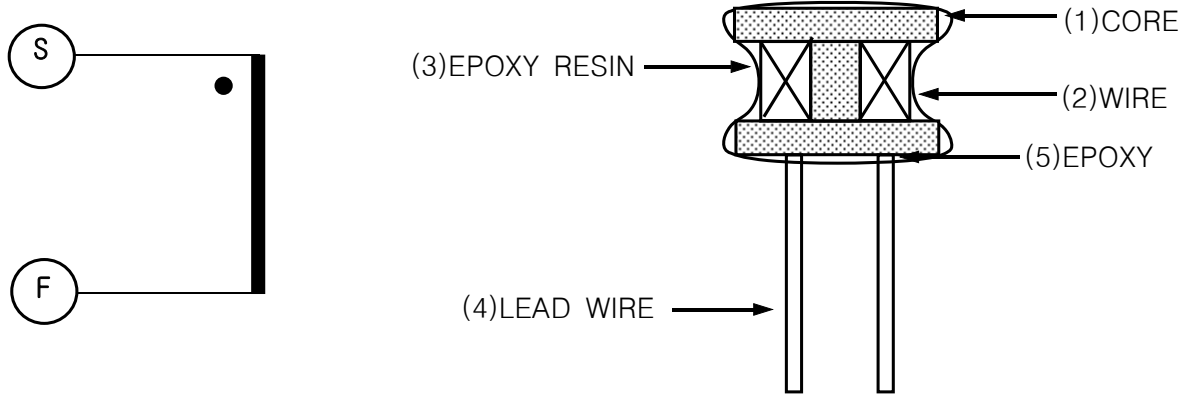

8. MATERIAL LIST

NO	I T E M	MATERIAL & DIMENSION	MANUFACTURE	REMARK
1	C O R E	S6,SD6,J6 DR 4 x 5.5mm	JAW SHIANQ CORPORATION CO.,LTD. ZHAOYUAN FLYING ELECTRONIC CO.,LTD. JIACI(ZHUHAI)ELECTRONICS CO.,LTD.	
2	W I R E	2UEW 0.23Ø	DONG YANG ELECTRONICS CO., LTD. ELEKTRISOLA CO., LTD	E102761S E210918
3	EPOXY RESIN	DP-402NH-P 930A.B	DAE JOO FINE CHEMICAL CO., LTD. SAM SIN CHEMICAL CO.,LTD.	
4	LEAD WIRE	TPC 0.5Ø CP-WIRE 0.5Ø	SAMATRON CO.,LTD IL-KWANG ELECTRONIC MATERIALS CO.,LTD.	
5	EPOXY	6020H	GUANGZHOU WELLS CHEMICAL CO.,LTD.	
6	SOLDER BAR	HSE-09	HEESUNG ENGINEERING CO.,LTD.	
-	FLUX	F181 SF-A-2	ZHUHAI FRIEND INDUSTRIAL CO.,LTD. SOLUX CO.,LTD.	
-	INK	270BK	DOMINO KOREA CO.,LTD.	

NO	REVISION	DATE	CHECK	DRAWN	CHECKED	APPROVED
1						
2						
3						
4						

CUSTOMER :

<b>SPECIFICATION</b>		SHEET NO.	6 OF 7
		D A T E	2008. 5. 10.
PART NAME	Radial Inductor	MODEL NAME	
PART NO.	DR1-10uH-T.B	DESCRIPTION	DR 4 × 5.5mm

9. TABLE OF STANDARD CHARACTERISTICS OF MATERIALS

PROPERTY UNIT MATERIAL	$\mu\text{iac}$ $\pm 25\%$	WORKING FREQUENCY	Bms	TC	$\rho$	d	$\alpha\mu\text{r}$	TAN $\sigma/\mu\text{i}$
		MHZ	GAUSS	°C	$\Omega\text{-cm}$	$\text{g}/\text{cm}^3$	$10^{-6}$	$10^{-6}(\text{MHZ})$
S6	10	0.01-0.5	2700	100	$10^7$	4.7~4.9	4	14(0.01) 40(0.5)

NO	REVISION	DATE	CHECK	DRAWN	CHECKED	APPROVED
1						
2						
3						
4						

CUSTOMER :

<h1>SPECIFICATION</h1>		SHEET NO.	7 OF 7
		D A T E	2008. 5. 10.
PART NAME	Radial Inductor	MODEL NAME	
PART NO.	DR1-10uH-T.B	DESCRIPTION	DR 4 × 5.5mm

10. REMARK

DONG YANG ELECTRONICS IND CO LTD				E102761 (S)	
660-1 BANWOL-RI TAIAN-EWB HWASUNG-GUN, KYUNGGI-DO KOREA					
Mtl	Cost typ			ANSI	
Dsg	BC	OC	Type	TI	
AI-EIW	Polyesterimide	Polyamideimide	MW35	200	
EIW	Polyesterimide		MW30	180	
NY-EIW	Polyester- amide-imide	Polyamide	MW96	180	
NY-PEW	Polyester	Polyamide	MW24	155	
NY-PEW(F)	Polyester	Polyamide	MW24	155	
NY-UEW	Polyurethane	Polyamide	MW23	130	
UEW	Polyurethane	-	MW75	130	

Marking: Company name or "E102761" and material designation or marked designation on package or reel, and recognized Component Mark.

**08MW2** January 15, 1997  
**Component - Magnet Wire**

**ELEKTRISOLA (MALAYSIA) SDN BHD** **E143312 (M)**

(B - cont. from A card)

Polysol 155	P155	Polyurethane	—	MW-79,	155,
				MW-75	130
Polysol 155g	Pg155	Polyurethane	—	MW75	130
Polysol 155p	Pp155, Gp155	Polyurethane	—	MW79	155
Polysol 160	P160	Polyurethane	—	MW-79	155
Polysol 180	P180, G180	Polyurethane	—	MW79	155

Marking: Company name, material designation or marked designation on package or reel and Recognized Component Mark.

See General Information Preceding These Recognitions.  
For use only in equipment where the acceptability of the combination is determined by Underwriters Laboratories Inc.  
Reports: March 13, 1992; March 13, 1992; March 13, 1992; March 13, 1992; March 13, 1992.

Replaces E143312E143312B dated April 20, 1992.

768673002 N3347 **Underwriters Laboratories Inc.®** 011/0210461

NO	REVISION	DATE	CHECK	DRAWN	CHECKED	APPROVED
1						
2						
3						
4						