

S P E C I F I C A T I O N

APPLICATION FOR APPROVAL OF

ITEM	:	RADIAL INDUCTOR
DESCRIPTION	:	DR 4 × 5.5mm
CODE NO	:	DR1) 2.2uH(BULK & TAPING)
MODEL NO	:	

This space is used for customer's approval

DATE : 2008. 5. 9.

DRAWN BY Y. H. JEON	DATE 2008. 5. 9.
CHECKED BY	DATE.
APPROVED BY J. G. KIM	DATE 2008. 5. 9.

CUSTOMER :

<h1>SPECIFICATION</h1>		SHEET NO.	1 OF 9
		D A T E	2008. 5. 9.
PART NAME	Radial Inductor	MODEL NAME	
PART NO.	DR1-2.2uH-T.B	DESCRIPTION	DR 4 × 5.5mm

1. GENERAL SPECIFICATION

1) SCOPE

This specification applies to part number 2.2uH (RADIAL INDUCTOR or PEAKING COIL) for use in electronic appliances which is supplied for

2. MECHANICAL CHARACTERISTIC

PEAKING COIL shall conform in size, dimension, and other mechanical properties, to the part drawing attached here to.

- 1) Marking : PEAKING COIL shall be permanently and legibly marked with the part number on the specification position.
- 2) Terminal strength : Terminal shall withstand for 30 seconds without breakdown on losing when a static load of 2 Kg is applied in the drawing direction to the terminal at the point where the external load.

3. ENVIRONMENTAL & LIFE CHARACTERISTIC

- 1) Temperature rise : Temperature rise of the each winding and core shall be less than ambient + 65°C , when the PEAKING COIL continuously operated at full load(test load) until constant temperature is attained.
- 2) Heat-resistance : Immediately after PEAKING COIL being placed in room for 96 Hours maintained AT 105°C ± 2°C ambient temperature, the PEAKING COIL shall conform with the above part paragraph (4) and also insulation resistance shall be more than 100 MΩ.
- 3) Moisture resistance : Immediately after PEAKING COIL being placed in room for 120 Hours in such humidity chamber this is maintained at 90 - 95% relative humidity and 55°C ± 2°C temperature and wiped a drop of water, PEAKING COIL shall conform with the above paragraph(4) and also insulation shall be the 10 MΩ.
- 4) Safety consideration : PEAKING COIL shall meet all the requirements subject to IEC-950 standards for safety of information technology equipment including electrical business equipment.
- 5) Solderability : Dip pads in RMA flux, 96.5/0.5/3 solder (Sn/Cu/Ag)at 260°C for 5±2 seconds

NO	REVISION	DATE	CHECK	DRAWN	CHECKED	APPROVED
1						
2						
3						
4						

CUSTOMER :

4. APPEARANCE & DIMENSION (UNIT:m/m)		SHEET NO.	2 OF 9
SPECIFICATION		D A T E	2008. 5. 10.
		MODEL NAME	
PART NAME	Radial Inductor	DESCRIPTION	DR 4 × 5.5mm
PART NO.	DR1-2.2uH-T.B		

1. APPEARANCE & DIMENSION (UNIT:m/m)

MARKING: 2R2K or 2R2

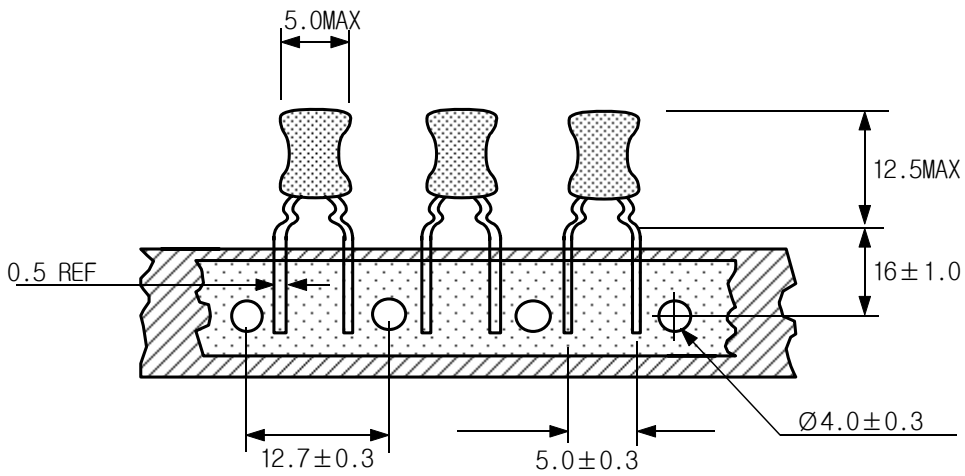
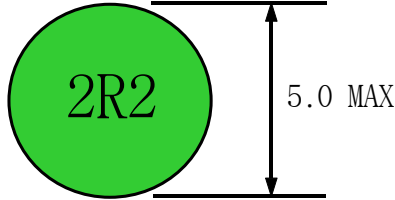

NO	REVISION	DATE	CHECK	DRAWN	CHECKED	APPROVED
1						
2						
3						
4						



NAMSUN ELECTRONICS CO.,LTD

CUSTOMER :

<h1>SPECIFICATION</h1>		SHEET NO.	3 OF 9
		D A T E	2008. 5. 9.
PART NAME	Radial Inductor	MODEL NAME	
PART NO.	DR1-2.2uH-T.B	DESCRIPTION	DR 4 × 5.5mm

4. APPEARANCE & DIMENSION (UNIT:m/m)

Marking : 2R2K or 2R2

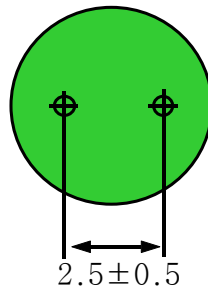
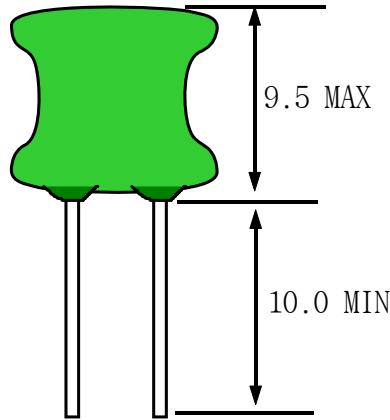
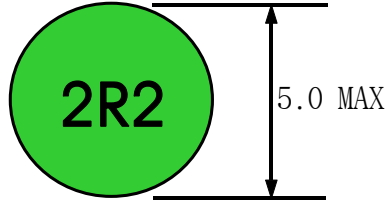

NO	REVISION	DATE	CHECK	DRAWN	CHECKED	APPROVED
1						
2						
3						
4						

CUSTOMER :

<h1>SPECIFICATION</h1>		SHEET NO.	4 OF 9
		D A T E	2008. 5. 9.
PART NAME	Radial Inductor	MODEL NAME	
PART NO.	DR1-2.2uH-T.B	DESCRIPTION	DR 4 × 5.5mm

5. WINDING SPEC

START & FINISH	TYPE OF WIRE	T U R N S	WINDING METHODE
	2UEW 0.35 Ø	<u>9.5</u> Ts REF	SOLENOID WINDING [C . C . W]

6. ELECTRICAL CHARACTERISTIC

NO	I T E M	MESURE	SPECIFICATION	REMARKS
1	INDUCTANCE	START & FINISH	<u>2.2</u> [uH] ± 20 [%]	HIOKI3522 LCR METER at 1kHz 1V
2	DC RESISTANCE	START & FINISH	<u>0.05</u> [Ω] MAX	WHEATSTONE BRIDGE TYPE 2755
3	DIELECTRIC WITHSTANDING TEST	COIL & CORE	AC <u>1</u> [KV] , FREQUANCY <u>60</u> [Hz] , <u>1</u> MINUTES, CUT OFF CURRENT <u>2</u> [mA]	NO BREAKDOWN
4	INSULATION RESISTANCE	COIL & CORE	DC <u>500</u> [V] , <u>100</u> [MΩ] MIN	DM-500AD

NO	REVISION	DATE	CHECK	DRAWN	CHECKED	APPROVED
1						
2						
3						
4						

CUSTOMER :

<h1>SPECIFICATION</h1>		SHEET NO.	5 OF 9
		D A T E	2008. 5. 9.
PART NAME	Radial Inductor	MODEL NAME	
PART NO.	DR1-2.2uH-T.B	DESCRIPTION	DR 4 × 5.5mm

7. SCHEMATIC DIAGRAM

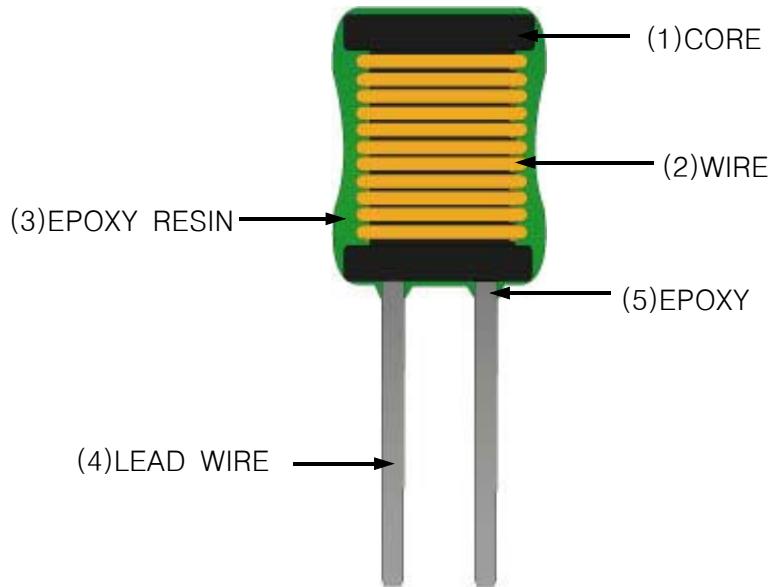
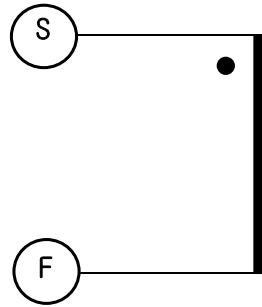

NO	REVISION	DATE	CHECK	DRAWN	CHECKED	APPROVED
1						
2						
3						
4						

CUSTOMER :

SPECIFICATION		SHEET NO.	6 OF 9
		D A T E	2008. 5. 9.
PART NAME	Radial Inductor	MODEL NAME	
PART NO.	DR1-2.2uH-T.B	DESCRIPTION	DR 4 × 5.5mm

8. MATERIAL LIST

NO	I T E M	MATERIAL & DIMENSION	MANUFACTURE	REMARK
1	C O R E	SGB,DGB,JA3 DR 4 x 5.5mm	JAW SHIANQ CORPORATION CO.,LTD. ZHAOYUAN FLYING ELECTRONIC CO.,LTD. JIACI(ZHUHAI)ELECTRONICS CO.,LTD.	
2	W I R E	2UEW 0.35Ø 2UEW 0.35Ø COPPER-WIRE	DONG YANG ELECTRONICS CO., LTD. ELEKTRISOLA CO., LTD CHUNHUI ELECTRICAL APPLANCES CO.,LTD.	E102761S E210918
3	EPOXY RESIN	DP-402NH-P 930A.B	DAE JOO FINE CHEMICAL CO., LTD. SAM SIN CHEMICAL CO.,LTD.	
4	LEAD WIRE	TPC 0.5Ø TPCS 0.5Ø	SAMATRON CO.,LTD IL-KWANG ELECTRONIC MATERIALS CO.,LTD. YEHUA ELECTRON MATERIAL LIMITED CO.,LTD.	
5	EPOXY	6020H	GUANGZHOU WELLS CHEMICAL CO.,LTD.	
-	SOLDER BAR	HSE-09	HEESUNG ENGINEERING CO.,LTD. JIAMENG CO.,LTD.	
-	FLUX	F181 SF-A-2	ZHUHAI FRIEND INDUSTRIAL CO.,LTD. SOLUX CO.,LTD.	
-	INK	270BK	DOMINO KOREA CO.,LTD.	

9. TABLE OF STANDARD CHARACTERISTICS OF MATERIALS

PROPEY UNIT MATERIAL	μ iac ±25%	Bms GAUSS	WORKING Frequency(MHZ)	Tc °C	ρ Ω -cm	d g/cm ³	TANσ/ μ i 10 ⁻⁶ (MHZ)	$\alpha\mu$ 10 ⁻⁶
SGB	300	3300	0.1~2.0	150	10 ⁷	4.7 ~ 4.9	15(0.1) 80(2)	25

NO	REVISION	DATE	CHECK	DRAWN	CHECKED	APPROVED
1						
2						
3						
4						

CUSTOMER :

<h1>SPECIFICATION</h1>		SHEET NO.	7 OF 9
		D A T E	2008. 5. 9.
PART NAME	Radial Inductor	MODEL NAME	
PART NO.	DR1-2.2uH-T.B	DESCRIPTION	DR 4 × 5.5mm

10-1 REMARK

DONG YANG ELECTRONICS IND CO LTD			E102761 (S)	
660-1 BANWOL-RI TAIAN-EWB HWASUNG-GUN, KYUNGGI-DO KOREA				
Mtl	Cost typ		ANSI	
Dsg	BC	OC	Type	TI
AI-EIW	Polyesterimide	Polyamideimide	MW35	200
EIW	Polyesterimide		MW30	180
NY-EIW	Polyester- amide-imide	Polyamide	MW96	180
NY-PEW	Polyester	Polyamide	MW24	155
NY-PEW(F)	Polyester	Polyamide	MW24	155
NY-UEW	Polyurethane	Polyamide	MW23	130
UEW	Polyurethane	-	MW75	130

Marking: Company name or "E102761" and material designation or marked designation on package or reel, and recognized Component Mark.

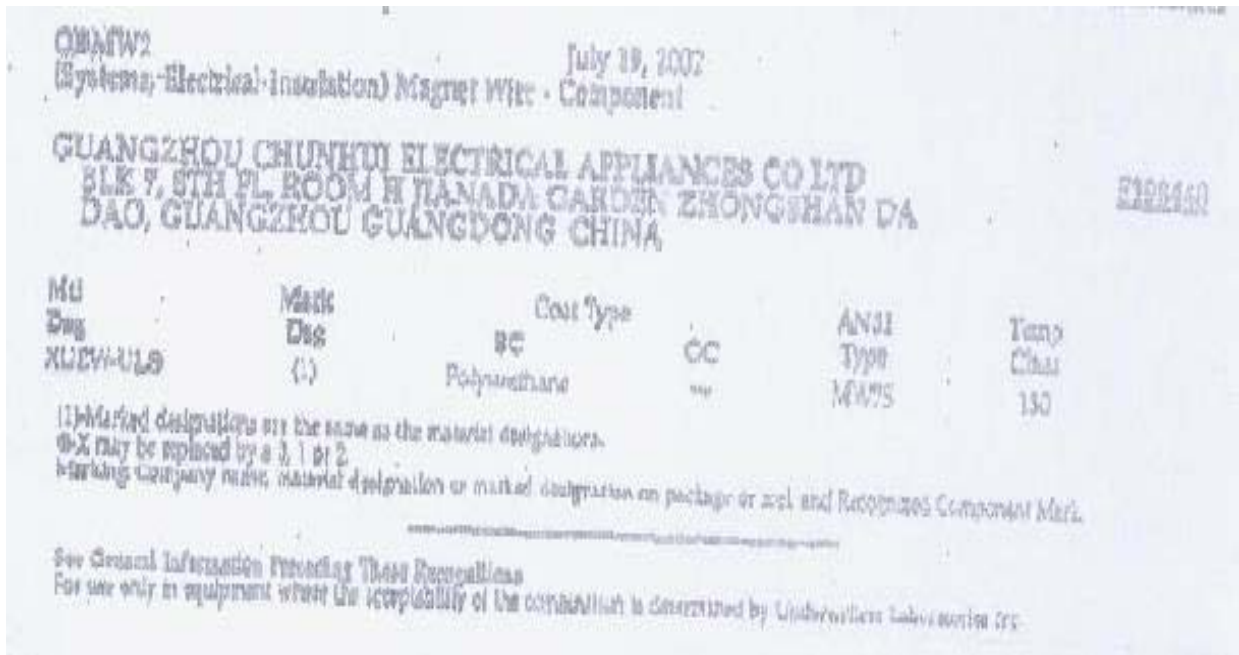

NO	REVISION	DATE	CHECK	DRAWN	CHECKED	APPROVED
1						
2						
3						
4						

CUSTOMER :

<h1>SPECIFICATION</h1>		SHEET NO.	8 OF 9
		D A T E	2008. 5. 9.
PART NAME	Radial Inductor	MODEL NAME	
PART NO.	DR1-2.2uH-T.B	DESCRIPTION	DR 4 × 5.5mm

10-2 REMARK

OBMW2 January 15, 1997
Component - Magnet Wire

ELEKTRISOLA (MALAYSIA) SDN BHD **E143312 (M)**
(B - cont. from A card)

Polysol 155	P155	Polyurethane	—	MW-79,	155,
				MW-75	130
Polysol 155g	Pg155	Polyurethane	—	MW75	130
Polysol 155p	Pp155,Gp155	Polyurethane	—	MW79	155
Polysol 160	P160	Polyurethane	—	MW-79	155
Polysol 180	P180,G180	Polyurethane	—	MW79	155

Marking: Company name, material designation or marked designation on package or reel and Recognized Component Mark.

See General Information Preceding These Recognitions.
 For use only in equipment where the acceptability of the combination is determined by Underwriters Laboratories Inc.
 Reports: March 13, 1992; March 13, 1992; March 13, 1992; March 13, 1992; March 13, 1992.

Replaces E143312E143312B dated April 20, 1992.

768673002 N3347 **Underwriters Laboratories Inc.®** 011/0210461

NO	REVISION	DATE	CHECK	DRAWN	CHECKED	APPROVED
1						
2						
3						
4						

CUSTOMER :

SPECIFICATION		SHEET NO.	9 OF 9
		D A T E	2008. 5. 9.
PART NAME	Radial Inductor	MODEL NAME	
PART NO.	DR1-2.2uH-T.B	DESCRIPTION	DR 4 × 5.5mm

11. INSPECTION DATA

NO	INDUCTANCE	DCR	내전압	절연저항
SPEC	2.2uH ± 20%	0.05[Ω] MAX	AC 1.0KV 1분 MIN	DC 500V 100MΩ MIN
1	2.03	0.02	OK	OK
2	2.1	0.022	OK	OK
3	2.09	0.021	OK	OK
4	2.12	0.02	OK	OK
5	2.21	0.022	OK	OK
6	2.15	0.023	OK	OK
7	2.04	0.02	OK	OK
8	1.98	0.021	OK	OK
9	1.94	0.021	OK	OK
10	2.06	0.02	OK	OK
X	2.072	0.021		
MIN	1.94	0.02		
MAX	2.21	0.023		

NO	REVISION	DATE	CHECK	DRAWN	CHECKED	APPROVED
1						
2						
3						
4						