

승 인	
정식승인	()
한도승인	()

SPECIFICATIONS

CUSTOMER	
ITEM	LINE FILTER
MODEL NAME	NS-103
PART No	UU1620-10mH(V)
DATE	2010-05-07

검 토	심 사	승 인
승인유효기간	승인일로부터	년

신청회사명	 남선전자주식회사	TEL	02-2689-9418
		FAX	02-2689-8628
주 소	Na-3506, Chungang Circulation Complex, 1258 Kurobon-dong, Kuro-Ku, Seoul, Korea, 152-721		

개 정 이 력

CUSTOMER				MODEL NO	NS-103
PART NO		UU1620-10mH(V)		ITEM	LINE FILTER
NO	DATA	Page	개 정 항 목	개 정 사 유	확인
1	2010-05-07			초도발행	
2					
3					
4					
5					
6					
7					
8					
9					
10					
11					
12					
13					
14					

NAMSUN ELECTRONICS CO., LTD.

Na-3506, Chungang Circulation Complex, 1258
 Kurobon-dong, Kuro-Ku, Seoul, Korea, 152-721
 TEL: 02-2689-9418 , FAX: 02-2689-8628

DESIGN	CHECK	APPROVAL
FILE NO.	SH - 070101 - 07	

APPROVAL SHEET

DATE

2010-05-07

PAGE

1 / 7

CUSTOMER			
PART NAME	LINE FILTER	MODEL NO.	NS-103
PART NO.	UU1620-10mH(V)	SIZE NO.	UU 1620 - V

1. DIMENSION (UNIT:mm)

< TOP VIEW >

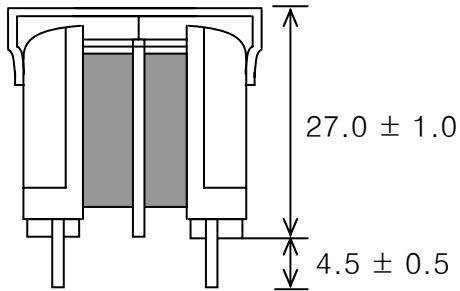

< FRONT VIEW >

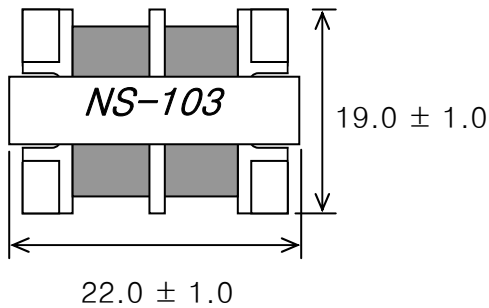

< SIDE VIEW >

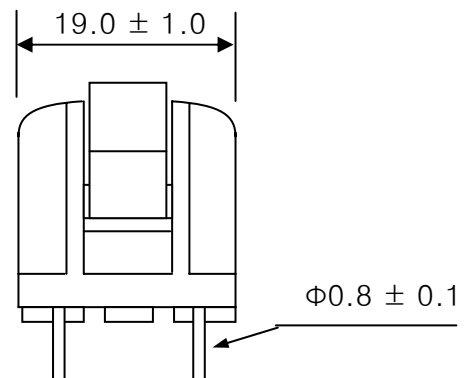

< BOTTOM VIEW >

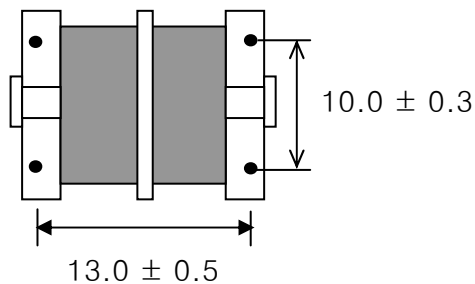

NAMSUN ELECTRONICS CO., LTD.

Na-3506, Chungang Circulation Complex, 1258
Kurobon-dong, Kuro-Ku, Seoul, Korea, 152-721
TEL: 02-2689-9418 , FAX: 02-2689-8628

DESIGN

CHECK

APPROVAL

개발실
김영라
10.05.07

개발실
이상순
10.05.07

개발실
노성복
10.05.07

FILE NO.

SH - 070101 - 07

APPROVAL SHEET

DATE

2010-05-07

PAGE

2 / 7

CUSTOMER

PART NAME

LINE FILTER

MODEL NO.

NS-103

PART NO.

UU1620-10mH(V)

SIZE NO.

UU 1620 - V

2. SCHEMATIC DIAGRAM

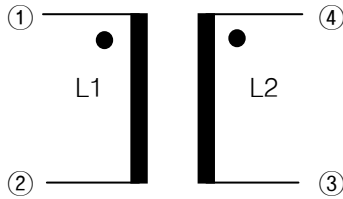

WINDNG

BOTTOM VIEW

C.C.W

N.C PIN

REMOVE PIN

3. WINDING SPECIFICATION

WINDING ORDER	COIL	TERMINAL (S - F)	WIRE	TURNS (Ts)	WINDING METHOD
1	L1	1 - 2	2 UEW ϕ 0.5 (AWG #)	65 Ts \pm 10T	SOLENOID WINDING
2	L2	4 - 3			SOLENOID WINDING

4. INSULATION

NO	COIL	THICK (mm) X WIDTH (mm)	TURNS (Ts)	MANUFACTURE
1	L1			POLYESTER FILM TAPE (Cat No. DTS-204)
2	L2			
CORE FIXING TAPE				

 **NAMSUN ELECTRONICS CO., LTD.**

Na-3506, Chungang Circulation Complex, 1258
Kurobon-dong, Kuro-Ku, Seoul, Korea, 152-721
TEL: 02-2689-9418 , FAX: 02-2689-8628

DESIGN

CHECK

APPROVAL

개발실
김영라
10.05.07

개발실
이상순
10.05.07

개발실
노성복
10.05.07

FILE NO.

SH - 070101 - 07

APPROVAL SHEET

DATE

2010-05-07

PAGE

3 / 7

CUSTOMER

PART NAME

LINE FILTER

MODEL NO.

NS-103

PART NO.

UU1620-10mH(V)

SIZE NO.

UU 1620 - V

5. ELECTRICAL CHARACTERISTICS

NO	ITEM	TERMINAL	SPECIFICATION	REMARKS
5-1	INDUCTANCE	L1 (1 - 2)	10 mH MIN	LEADER 745 LCR - METER at 1.0 KHz. 1.0V (25 °C)
		L2 (4 - 3)		
5-2	DIFFERENCE INDUCTANCE	L1 - L2	0.5 mH MAX	
5-3	DC RESISTANCE	L1 (1 - 2)	2.0ohm MAX	WHEATSTONE BRIDGE (Y.E.W 2755)
		L2 (4 - 3)		
5-4	DIELECTRIC STRENGTH	L1 COIL - L2 COIL	AC <u>2.0 KV</u> r.m.s (1 MINUTE)	CUT OFF CURRENT : 5 mA TOS - 8850
		L1 COIL - L2 COIL	AC <u>2.0 KV</u> r.m.s (1 MINUTE)	
5-5	INSULATION RESISTANCE	COIL - COIL	100 M ohm MIN at DC 500V	TOS - 8850

 **NAMSUN ELECTRONICS CO., LTD.**

Na-3506, Chungang Circulation Complex, 1258
Kurobon-dong, Kuro-Ku, Seoul, Korea, 152-721
TEL: 02-2689-9418 , FAX: 02-2689-8628

DESIGN

CHECK

APPROVAL

개발실

김영라

10.05.07

개발실

이상순

10.05.07

개발실

노성복

10.05.07

FILE NO.

SH - 070101 - 07

APPROVAL SHEET

DATE

2010-05-07

PAGE

4 / 7

CUSTOMER

PART NAME

LINE FILTER

MODEL NO.

NS-103

PART NO.

UU1620-10mH(V)

SIZE NO.

UU 1620 - V

6. SECTION DIAGRAM

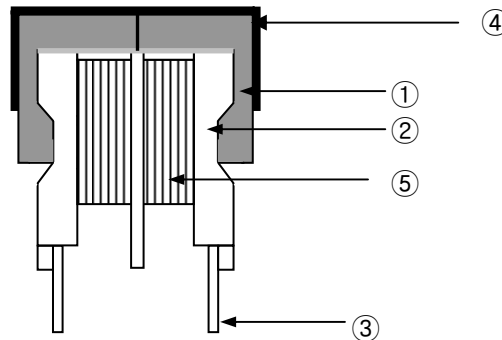

NO	COMPONENT	NAME OF MATERIAL	MANUFACTURER OF MATERIAL	REMARKS
1	CORE	GP-9 (UU 1620) R10K (UU 1620)	SAMWHA ELECTRONICS CO.,LTD. DMEGC MAGNETICS CO.,LTD	
2	BASE	PHENOL 94V-0 PF2736(A)(B) TYPE [UU1620(V) 4PIN)	BAKELITE GESELLSCHAFT MBH	E61040(M)
3	PIN	CP-WIRE (Sn 100%)	ILKWANG ELECTRONIC MATERIALS CO.,LTD.	
4	SPRING NOLDER	STANINLESS STEEL SUS31	TAEKYUNG ELECTRONICS. JINWON BOBBIN CO., LTD.	
5	WIRE	POLYURETHANE UEW 0.50φ	TAIHAN ELECTRIC WIRE CO., LTD. CNI CABLE CO.,LTD. NAMHAE ELECTRONICS CO.,LTD.	E109312(N) E210918
6	INSULATION TAPE	POLYESTER FILM TAPE T=0.025T (CLARITY)	HYUNDAI CHEMICAL CO.,LTD. DUCKSUNG TAPE CO.,LTD.	E162848(S) E105147(S)
7	FLUX	HDF 102	HANDOK FLUX	
8	SOLDER	SN99.5%,CU0.5%	DONGBU NANNONG CHEMICAL CO.,LT	
9	VARNISH	SR - 337	SE GYE CHEMICAL CO.,LTD.	
10	MARKING INK	BON - MARQUE	T & K TOKA	
11	GAP	NO GAP		

NAMSUN ELECTRONICS CO., LTD.

Na-3506, Chungang Circulation Complex, 1258
Kurobon-dong, Kuro-Ku, Seoul, Korea, 152-721
TEL: 02-2689-9418 , FAX: 02-2689-8628

DESIGN

CHECK

APPROVAL

개발실

개발실

개발실

김영라

이상순

노성복

10.05.07

10.05.07

10.05.07

FILE NO.

SH - 070101 - 07

APPROVAL SHEET

DATE 2010-05-07
PAGE 5/7

CUSTOMER			
PART NAME	LINE FILTER	MODEL NO.	NS-103
PART NO.	UU1620-10mH(V)	SIZE NO.	UU 1620 - V

TAIHAN ELECTRIC WIRE CO., LTD.
194-15 1-KA HOEHYUN-DONG CHUNG-KU CPO
BOX 2624, SEOUL KOREA

E 109312 (N)

Mtl Dsg	Coat type BC	Overcoat	ANSI Type	T1
Magnet wire.				
EI-AIW	Ester-imide imide	Polyamide-imide	MW35.73	200
AL EI-AIW	Ester-imide	Polyamide-imide	MW35	240
EIW	Ester-imide	-	MW30.72	180
EIW-N	Ester-imide	Polyamide	MW76	180
AIW	Polyamide-imide	-	-	220
PEW-N	Polyester	Polyamide	MW76	180
SEIW	Solderable Polyester-imide	-	MW77	180
UEW	Polyurethane	-	MW75	130
UEW-N	Polyurethane	Polyamide	MW80	155

Reports : April 2, 1987; April 2, 1987; April 2, 1987; April 2, 1987: April 2, 1987; April 2, 1987' April 2, 1987; April 2, 1987; April 2, 1987.

CNI CABLE CO.,LTD

E 210918

312-16, DEUKSAN-DONG,
ASAN-SI, GYEONGGI-DO, 336-120, REPUBLIC OF KOREA

Mtl Dsg	Mark Dsg	Coat Type		ANSI Type	Temp Class
		BC	OC		
DSUEW-100	(1)	Polyurethane	-	MW75C	130#
UEW	(1)	Polyurethane	None	MW79	155
				MW75	130#
PEW	(1)	Polyester	None	MW30	180
				MW5	155#

(1) Marked designations are the same as the material designations.

- This wire may perform better than its temperature rating reflects. Hence, It may not be suitable to use in an insulation system thermal aging program.

 **NAMSUN ELECTRONICS CO., LTD.**

Na-3506, Chungang Circulation Complex, 1258
Kurobon-dong, Kuro-Ku, Seoul, Korea, 152-721
TEL:02-2689-9418 , FAX:02-2689-8628

DESIGN	CHECK	APPROVAL
개발실 김영라 10.05.07	개발실 이상순 10.05.07	개발실 노성복 10.05.07
FILE NO.	SH - 070101 - 07	

APPROVAL SHEET

DATE

2010-05-07

PAGE

6 / 7

CUSTOMER

PART NAME

LINE FILTER

MODEL NO.

NS-103

PART NO.

UU1620-10mH(V)

SIZE NO.

UU 1620 - V

BAKELITE AG

E 61040 (M)

POSTFACH 7154 58609, ISERLOHN-LETMATH FED
REP GERMANY

Phenolic molding compound(PF), desingnated "Rutaform" or "furnished in the form of pellets or powder

PF2836@	BK	1.50	94V-0	150	150	150	0	2	~	5	~
PF2736@	NC,GN	0.81	94V-0	150	150	150	0	2	~	5	~
	BK										
	ALL	0.81	94V-1	150	150	150	0	2	~	5	~
	ALL	1.50	94V-0	150	150	150	0	2	0	~	~
		3.00	94V-0	150	150	150	0	2	0	5	
PF2560@	ALL	1.50	94V-1	150	150	150	~	~	~	~	~
	BK,NC	1.50	94V-0	150	150	150	~	~	~	~	~
	ALL	3.00	94V-0	150	150	150	~	~	~	~	~
PF31@	ALL	1.50	94V-1	150	150	150	1	1	~	6	~
		3.00	94V-0	150	150	150	0	1	~	~	~
PF2744@	ALL	1.50	94V-0	150	150	150	0	1	~	5	~
PF2855@	ALL	3.00	94V-0	150	150	150	0	3	~	5	~
PF6506@	ALL	1.50	94V-0	150	150	150	0	2	~	5	~

 **NAMSUN ELECTRONICS CO., LTD.**

Na-3506, Chungang Circulation Complex, 1258
Kurobon-dong, Kuro-Ku, Seoul, Korea, 152-721
TEL: 02-2689-9418 , FAX: 02-2689-8628

DESIGN

CHECK

APPROVAL

개발실

김영라

10.05.07

개발실

이상순

10.05.07

개발실

노성복

10.05.07

FILE NO.

SH - 070101 - 07

<h1>APPROVAL SHEET</h1>	DATE	2010-05-07
	PAGE	7 / 7

CUSTOMER			
PART NAME	LINE FILTER	MODEL NO.	NS-103
PART NO.	UU1620-10mH(V)	SIZE NO.	UU 1620 - V

HYUN DAI CHEMICAL CO., LTD
 258 YEULMI-RI SILCHON-MYON KWANGJU
 KYONGGI-DO 464-870 KOREA

E 162848 (S)

Polyester tape with aprille adhedive, cat. no. 800 for use at temperature not mxddading 190 c.
 Marking company name. catalog daeignation and temperature rating ptinted on darion .wrapper
 or core.

See Genaral informtion precading three recognitiona

For use only equipment where the adceptabination la datermined by undarwil.
 ars Laboratorles inc.

Report October 20. 1994.

1.06E+08 underwriters Laboratoles inc. Dil/0264017

and Recognized Component Mark.

DUCK SUNG TAPE CO LTD
 DAESUNG BLDG 677 JAYANG-DONG SUNGDONG-KU,
 SEOUL 133-190 KOREA

E 105147 (S)

Polyester film insulating tape,cat.no. DTS-204 rated 130 C.

Acetate cloth insulating tape,cat.no. 231 rated 105 C.

Glass cloth insulating tape,cat.no. 220-B rated 130 C.

Acetate cloth insulating tape,cat.no. DTS-230 rated 105 C.

Marking:Company name or trademark or "E105147" and catalog designation
 printed on carton, wrapper or core.

 Na-3506, Chungang Circulation Complex, 1258 Kurobon-dong, Kuro-Ku, Seoul, Korea, 152-721 TEL:02-2689-9418 , FAX:02-2689-8628	DESIGN	CHECK	APPROVAL
			
	FILE NO.	SH - 070101 - 07	