



# 개 정 이 력

CUSTOMER				MODEL NO	NSFH-104
PART NO		UU1116-100mH-H-TYPE		ITEM	LINE FILTER
NO	DATA	Page	개 정 항 목	개 정 사 유	확 인
1	2012-06-25			초도발행	
2					
3					
4					
6					
7					
8					
9					
10					
11					
12					
13					
14					

 **NAMSUN ELECTRONICS CO., LTD.**

Na-3506, Chungang Circulation Complex, 1258  
 Kurobon-dong, Kuro-Ku, Seoul, Korea, 152-721  
 TEL: 02-2689-9418 , FAX: 02-2689-8628

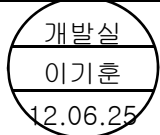
DESIGN	CHECK	APPROVAL
		
FILE NO.	NS - 6025-104	

# APPROVAL SHEET

DATE	2012-06-25
PAGE	1 / 6

CUSTOMER			
PART NAME	LINE FILTER	MODEL NO.	NSFH-104
PART NO.	UU1116 - 100mH	SIZE NO.	UU 1116 - H

## 1. DEMENSION (단위 : mm)

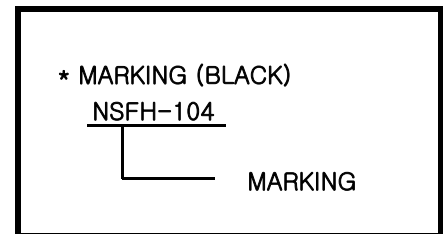

1) TOP VIEW

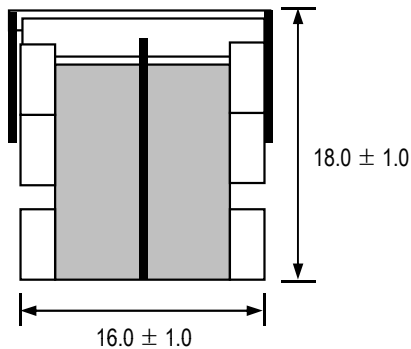

2) FRONT VIEW

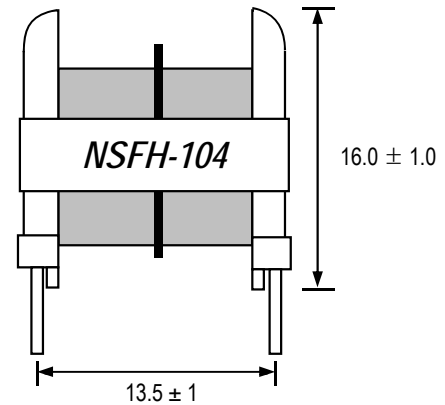

\*\*\* GAP : NO \*\*\*

3) SIDE VIEW

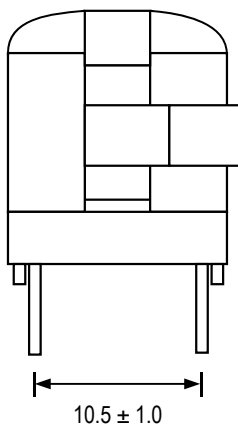

4) BOTTOM VIEW

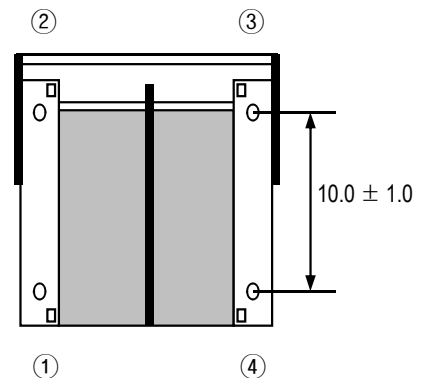

**NAMSUN ELECTRONICS CO., LTD.**

Na-3506, Chungang Circulation Complex, 1258  
Kurobon-dong, Kuro-Ku, Seoul, Korea, 152-721  
TEL:02-2689-9418 , FAX:02-2689-8628

DESIGN	CHECK	APPROVAL
개발실 이기훈 12.06.25	개발실 이상순 12.06.25	개발실 노성복 12.06.25
FILE NO.	NS - 6025-104	

# APPROVAL SHEET

DATE 2012-06-25  
PAGE 2 / 6

CUSTOMER			
PART NAME	LINE FILTER	MODEL NO.	NSFH-104
PART NO.	UU1116 - 100mH	SIZE NO.	UU 1116 - H

## 2. SCHEMATIC

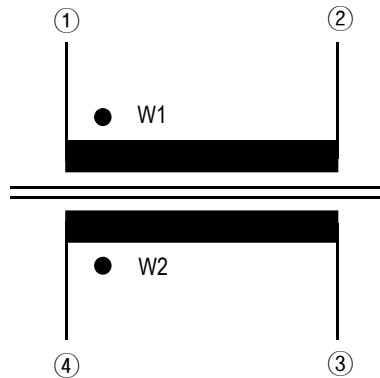

## 3. WINDING - SPECIFICATION

NO	PIN NUMBER		WIRE	TURNS	INSULATION			
	START	FINAL			MATERIAL	P/S TAPE THICKNESS (UNIT : mm)	TAPE TURNS	COLOR
W1	1	2	UEW 0.2Φ	250T ± 5T				
W2	4	3	UEW 0.2Φ	250T ± 5T				

**NAMSUN ELECTRONICS CO., LTD.**

Na-3506, Chungang Circulation Complex, 1258  
Kurobon-dong, Kuro-Ku, Seoul, Korea, 152-721  
TEL:02-2689-9418 , FAX:02-2689-8628

DESIGN	CHECK	APPROVAL
개발실 이기훈 12.06.25	개발실 이상순 12.06.25	개발실 노성복 12.06.25
FILE NO.	NS - 6025-104	

# APPROVAL SHEET

DATE 2012-06-25  
PAGE 3 / 6

CUSTOMER			
PART NAME	LINE FILTER	MODEL NO.	NSFH-104
PART NO.	UU1116 - 100mH	SIZE NO.	UU 1116 - H

## 4. ELECTRICAL

NO	ITEM	PIN NO	SPEC	REMARKS
1	INDUCTANCE	L1 , L2	100mH MIN.	at 1.0KHz 1.0V LEADER LCR-745
2	WITHSTANDING VOLATAGE	WINDING : CORE	AC1500VAC 1 MIN	

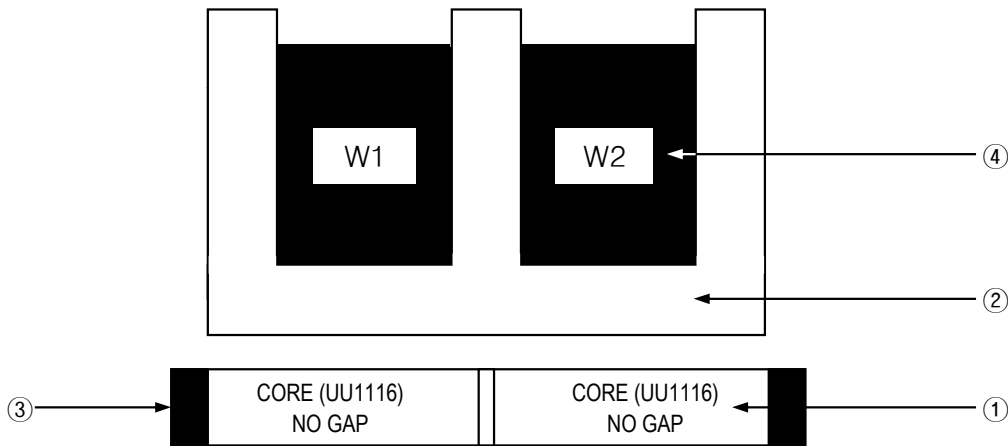

**NAMSUN ELECTRONICS CO., LTD.**

Na-3506, Chungang Circulation Complex, 1258  
Kurobon-dong, Kuro-Ku, Seoul, Korea, 152-721  
TEL:02-2689-9418 , FAX:02-2689-8628

DESIGN	CHECK	APPROVAL
개발실 이기훈 12.06.25	개발실 이상순 12.06.25	개발실 노성복 12.06.25
FILE NO.	NS - 6025-104	

# APPROVAL SHEET

DATE	2012-06-25
PAGE	4 / 6

CUSTOMER			
PART NAME	LINE FILTER	MODEL NO.	NSFH-104
PART NO.	UU1116 - 100mH	SIZE NO.	UU 1116 - H

## 5. MATERIAL LIST

NO	COMPONENT	NAME OF MATERIAL	MANUFACTURER OF COMPONENT	REMARKS
1	CORE	UU 1116 (HM-3B) UU 1116 (GP-9) UU 1116 (R10K)	ISU CO., LTD. SAM HWA ELECTRONICS CO., LTD. DMEGC MAGNETICS CO.,LTD	
2	BOBBIN	PHENOL 94V - 0 PF2736 [ UU1116 (H) 4PIN ]	BAKELITE GESELLSCHAFT MBH.	E 61040 (M)
	PIN	CP-WIRE (Sn 100%)	JINWON BOBBIN CO.,LTD.	
3	SPRING NOLDER	STANINLESS STEEL SUS31	DAEHYUN INDUSTRIAL JINWON BOBBIN CO.,LTD.	
4	WIRE	POLYURETHANE UEW 0.20Φ	TAIHAN ELECTRIC WIRE CO.,LTD. CNI CABLE CO.,LTD. NAMHEA ELECTRONICS CO.,LTD	E 109312 (N) E 210918
5	FLUX	LF - 715K	TAEWON CHEMICAL CO.,LTD.	
6	SOLDER	SN99.5%,CU0.5%	DONGBU NANNONG CHEMICAL CO.,LTD.	
7	VARNISH	SR - 337	SE GYE CHEMICAL CO.,LTD.	
8	MARKING INK	BON - MARQUE	T & K TOKA	
9	GAP	NO GAP		



Na-3506, Chungang Circulation Complex, 1258  
Kurobon-dong, Kuro-Ku, Seoul, Korea, 152-721  
TEL: 02-2689-9418 , FAX: 02-2689-8628

DESIGN	CHECK	APPROVAL
FILE NO.	NS - 6025-104	

# APPROVAL SHEET

DATE

2012-06-25

PAGE

5 / 6

CUSTOMER			
PART NAME	LINE FILTER	MODEL NO.	NSFH-104
PART NO.	UU1116 - 100mH	SIZE NO.	UU 1116 - H

- UL CARD -

BAKELITE AG

E 61040 (M)

POSTFACH 7154 58609, ISERLOHN-LETMATH FED  
REP GERMANY

Phenolic molding compound(PF), desingnated "Rutaform" or "furnished in the form of pellets or powder

PF2836@	BK	1.50	94V-0	150	150	150	0	2	~	5	~
● PF2736@	NC,GN	0.81	94V-0	150	150	150	0	2	~	5	~
	BK										
	ALL	0.81	94V-1	150	150	150	0	2	~	5	~
	ALL	1.50	94V-0	150	150	150	0	2	0	~	~
		3.00	94V-0	150	150	150	0	2	0	5	3
PF2560@	ALL	1.50	94V-1	150	150	150	~	~	~	~	~
	BK,NC	1.50	94V-0	150	150	150	~	~	~	~	~
	ALL	3.00	94V-0	150	150	150	~	~	~	~	~
PF31@	ALL	1.50	94V-1	150	150	150	1	1	~	6	~
		3.00	94V-0	150	150	150	0	1	~	~	~
PF2744@	ALL	1.50	94V-0	150	150	150	0	1	~	5	~
PF2855@	ALL	3.00	94V-0	150	150	150	0	3	~	5	~
PF6506@	ALL	1.50	94V-0	150	150	150	0	2	~	5	~

 **NAMSUN ELECTRONICS CO., LTD.**

Na-3506, Chungang Circulation Complex, 1258  
Kurobon-dong, Kuro-Ku, Seoul, Korea, 152-721  
TEL:02-2689-9418 , FAX:02-2689-8628

DESIGN

CHECK

APPROVAL

개발실  
이기훈  
12.06.25

개발실  
이상순  
12.06.25

개발실  
노성복  
12.06.25

FILE NO.

NS - 6025-104

# APPROVAL SHEET

DATE	2012-06-25
PAGE	6 / 6

CUSTOMER			
PART NAME	LINE FILTER	MODEL NO.	NSFH-104
PART NO.	UU1116 - 100mH	SIZE NO.	UU 1116 - H

**TAIHAN ELECTRIC WIRE CO., LTD.** **E 109312 (N)**

194-15 1-KA HOEHYUN-DONG CHUNG-KU CPO  
BOX 2624, SEOUL KOREA

Mti Dsg	Coat type	Overcoat	ANSI Type	Temp Class
Magnet wire.				
EI-AIW	Ester-imide imide	Polyamide-imide	MW35.73	200
AL EI-AIW	Ester-imide	Polyamide-imide	MW35	240
EIW	Ester-imide	-	MW30.72	180
EIW-N	Ester-imide	Polyamide	MW76	180
AIW	Polyamide-imide	-	-	220
PEW-N	Polyester	Polyamide	MW76	180
SEIW	Solderable Polyester-imide	-	MW77	180
● UEW	Polyurethane	-	MW75	130
UEW-N	Polyurethane	Polyamide	MW80	155

Reports : April 2, 1987; April 2, 1987; April 2, 1987; April 2, 1987: April 2, 1987; April 2, 1987; April 2, 1987; April 2, 1987; April 2, 1987.

**CNI CABLE CO., LTD** **E 210918**

312-16, DEUKSAN-DONG,  
ASAN-SI, GYEONGGI-DO, 336-120, REPUBLIC OF KOREA

Mti Dsg	Mark Dsg	Coat Type		ANSI Type	Temp Class
		BC	OC		
● DSUEW-100	(1)	Polyurethane	-	MW75C	130#
UEW	(1)	Polyurethane	None	MW79	155
				MW75	130#
PEW	(1)	Polyester	None	MW30	180
				MW5	155#

(1) Marked designations are the same as the material designations.

# - This wire may perform better than its temperature rating reflects. Hence, It may not be suitable to use in an insulation system thermal aging program.



Na-3506, Chungang Circulation Complex, 1258  
Kurobon-dong, Kuro-Ku, Seoul, Korea, 152-721  
TEL:02-2689-9418 , FAX:02-2689-8628

DESIGN	CHECK	APPROVAL
FILE NO.	NS - 6025-104	