

승 인	
정식승인	()
한도승인	()

SPECIFICATIONS

CUSTOMER	
ITEM	LINE FILTER
MODEL NAME	NSV-202
PART No	UU1014-2mH-V-TYPE
DATE	2019-02-05

검 토	심 사	승 인
승인유효기간	승인일로부터	년

신청회사명	남선전자주식회사	TEL	02-2689-9418
		FAX	02-2689-8628
주 소	Na-3506, Chungang Circulation Complex, 1258 Kurobon-dong, Kuro-Ku, Seoul, Korea, 152-721		

개 정 이 력

CUSTOMER				MODEL NO	NSV-202
PART NO		UU1014-2mH-V		ITEM	LINE FILTER
NO	DATA	Page	개 정 항 목	개 정 사 유	확인
1	2010-05-07			초도발행	
2	2019-02-05	2		UEWΦ0.30 에서 uewΦ0.32 로 WIRE 선경변경	
3					
4					
5					
6					
7					
8					
9					
10					
11					
12					
13					
14					

NAMSUN ELECTRONICS CO., LTD.

Na-3506, Chungang Circulation Complex, 1258
 Kurobon-dong, Kuro-Ku, Seoul, Korea, 152-721
 TEL:02-2689-9418 , FAX:02-2689-8628

DESIGN

개발실
추유섭
10.05.07

FILE NO.

CHECK

개발실
이상순
10.05.07

APPROVAL

개발실
조한석
10.05.07

NS - A05071

APPROVAL SHEET

DATE	2010-05-07
PAGE	1 / 9

CUSTOMER			
PART NAME	LINE FILTER	MODEL NO.	NSV-202
PART NO.	UU1014-2mH-V	SIZE NO.	UU 1014 - V

1. DIMENSION (UNIT:mm)

< TOP VIEW >

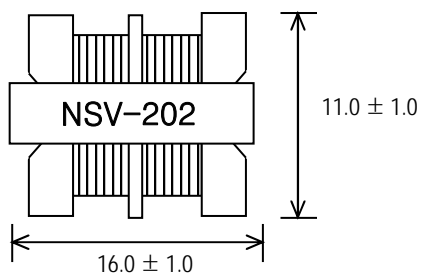

< FRONT VIEW >

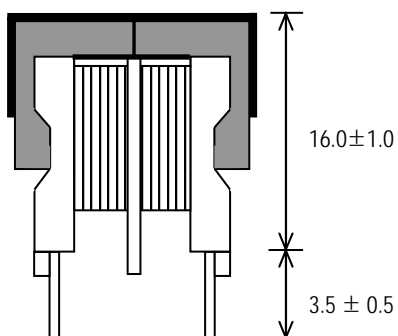

< SIDE VIEW >

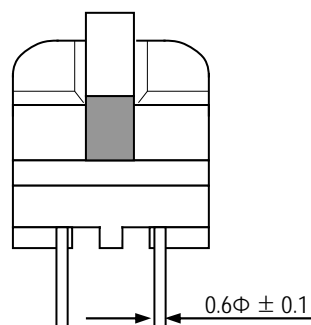

< BOTTOM VIEW >

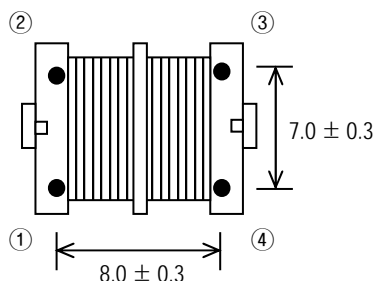

NAMSUN ELECTRONICS CO., LTD.

Na-3506, Chungang Circulation Complex, 1258
Kurobon-dong, Kuro-Ku, Seoul, Korea, 152-721
TEL:02-2689-9418 , FAX:02-2689-8628

DESIGN	CHECK	APPROVAL
개발실 추유섭 10.05.07	개발실 이상순 10.05.07	개발실 조한석 10.05.07
FILE NO.	NS - A05071	

APPROVAL SHEET

DATE 2010-05-07

PAGE 2 / 9

CUSTOMER

PART NAME

LINE FILTER

MODEL NO.

NSV-202

PART NO.

UU1014-2mH-V

SIZE NO.

UU 1014 - V

2. SCHEMATIC DIAGRAM

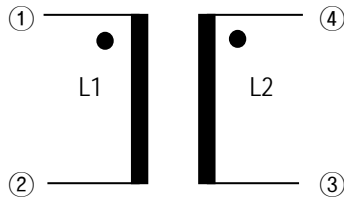

WINDNG

BOTTOM VIEW

C.C.W

N.C PIN

REMOVE PIN

3. WINDING SPECIFICATION

WINDING ORDER	COIL	TERMINAL (S - F)	WIRE	URNS (Ts)	WINDING METHOD
1	L1	1 - 2	2 UEW ϕ 0.32 (AWG #)	45Ts	SOLENOID WINDING
2	L2	4 - 3			SOLENOID WINDING

4. ELECTRICAL CHARACTERISTICS

NO	CLOSURE	TERMINAL NO.	SPECIFICATION	CONDITION
1	INDUCTANCE	1 - 2	2mH MIN	HP-4284A at 1KHz, 1Vrms
2	DC RESISTANCE	1 - 2	Ω MAX Ω MAX	WHEATSTONE BRIDGE TAPE 2755, TYPE 3220
3	LAYER SHORT		AC 1.4KV, 1 MIN.	
4	DIELECTRIC STRENGTH	L1 - L2 COIL - CORE	AC1.5KV, 10mA . 1 MIN.	KIKUSUI : TOS-5050 (CURRENT SENSITIVE:5mA)
5	INSULATION RESISTANCE		100 Mohm MIN at DC 500V	MEGOHM METER (SM-5E)

NAMSUN ELECTRONICS CO., LTD.

Na-3506, Chungang Circulation Complex, 1258
Kurobon-dong, Kuro-Ku, Seoul, Korea, 152-721
TEL:02-2689-9418 , FAX:02-2689-8628

DESIGN

CHECK

APPROVAL

 개발실
추유섭
10.05.07

 개발실
이상순
10.05.07

 개발실
조한석
10.05.07

FILE NO.

NS - A05071

APPROVAL SHEET

DATE	2010-05-07
PAGE	3 / 9

CUSTOMER			
PART NAME	LINE FILTER	MODEL NO.	NSV-202
PART NO.	UU1014-2mH-V	SIZE NO.	UU 1014 - V

5. ELECTRICAL CHARACTERISTICS

NO	ITEM	TERMINAL	SPECIFICATION	REMARKS
5-1	INDUCTANCE	L1 (1 - 2)	2 mH MIN	LEADER 745 LCR - METER at 1.0 KHz. 1.0V (25 °C)
		L2 (4 - 3)		
5-2	DIFFERENCE INDUCTANCE	L1 - L2	0.3 mH MAX	
5-3	DC RESISTANCE	L1 (1 - 2)	ohm MAX	WHEATSTONE BRIDGE (Y.E.W 2755)
		L2 (4 - 3)		
5-4	DIELECTRIC STRENGTH	L1 COIL - L2 COIL	AC 2.0 KV r.m.s (1 MINUTE)	CUT OFF CURRENT : 5 mA TOS - 8850
		L1 COIL - L2 COIL	AC 2.0 KV r.m.s (1 MINUTE)	
5-5	INSULATION RESISTANCE	COIL - COIL	100 M ohm MIN at DC 500V	TOS - 8850

NAMSUN ELECTRONICS CO., LTD.

76-29, GOCHEOK-DONG, GURO-GU, SEOUL, KOREA
TEL : (02) 2687-8088 FAX : (02) 2687-5821

DESIGN	CHECK	APPROVAL
--------	-------	----------

개발실 추유섭 10.05.07

개발실 이상순 10.05.07

개발실 조한석 10.05.07

FILE NO.

NS - A05071

APPROVAL SHEET

DATE 2010-05-07
PAGE 4 / 9

CUSTOMER			
PART NAME	LINE FILTER	MODEL NO.	NSV-202
PART NO.	UU1014-2mH-V	SIZE NO.	UU 1014 - V

6. SECTION DIAGRAM

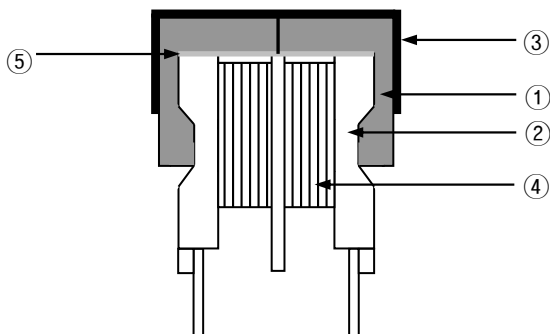

7. MATERIAL LIST

NO	COMPONENT	NAME OF MATERIAL	MANUFACTURER OF MATERIAL	REMARKS
1	CORE	GP-5/9 (UU 1014) HM-3 (UU 1014) R10K (UU 1014)	SAMWHA ELECTRONICS CO.,LTD. ISU CO.,LTD. DMEGC MAGNETICS CO.,LTD	
2	BASE	PHENOL RESIN (PF2736) 94V-0	BAKELITE GESELLSCHAFT MBH	E61040(M)
3	SPRING HOLDER	STAINLESS STEEL SUS 31	JIN BO INDUSTRIAL CO.	
4	WIRE	POLYURETHANE UEW 0.3Φ	TAIHAN ELECTRIC WIRE CO., LTD. DONGSUH ELECTRONICS CO.,LTD.	E109312(N) E210918
5	INSULATION TAPE	POLYESTER TAPE 0.025t x 4.5mm (Y)	HYUNDAI CHEMICAL CO.,LTD. DUCKSUNG TAPE CO.,LTD.	E162848(S) E105147(S)
6	VARNISH	DVA-1411	DAIHAN PAINT & INK CO.,LTD.	E93947(S)
7	SOLDER	SN98%,CU2%	ALPHA SOLDER CO.	

NAMSUN ELECTRONICS CO., LTD.

Na-3506, Chungang Circulation Complex, 1258
Kurobon-dong, Kuro-Ku, Seoul, Korea, 152-721
TEL:02-2689-9418 , FAX:02-2689-8628

DESIGN	CHECK	APPROVAL
개발실 추유섭 10.05.07	개발실 이상순 10.05.07	개발실 조한석 10.05.07
FILE NO.	NS - A05071	

APPROVAL SHEET

DATE 2010-05-07
PAGE 5 / 9

CUSTOMER			
PART NAME	LINE FILTER	MODEL NO.	NSV-202
PART NO.	UU1014-2mH-V	SIZE NO.	UU 1014 - V

TAIHAN ELECTRIC WIRE CO., LTD.

E 109312 (N)

194-15 1-KA HOEHYUN-DONG CHUNG-KU CPO
BOX 2624, SEOUL KOREA

Mtl Dsg	Coat type BC	Overcoat	ANSI Type	
Magnet wire.				T1
EI-AIW	Ester-imide imide	Polyamide-imide	MW35.73	200
AL EI-AIW	Ester-imide	Polyamide-imide	MW35	240
EIW	Ester-imide	-	MW30.72	180
EIW-N	Ester-imide	Polyamide	MW76	180
AIW	Polyamide-imide	-	-	220
PEW-N	Polyester	Polyamide	MW76	180
SEIW	Solderable Polyester-imide	-	MW77	180
UEW	Polyurethane	-	MW75	130
UEW-N	Polyurethane	Polyamide	MW80	155

Reports : April 2, 1987; April 2, 1987; April 2, 1987; April 2, 1987; April 2, 1987; April 2, 1987; April 2, 1987; April 2, 1987; April 2, 1987; April 2, 1987.

DONG SUH ELECTRONICS CO., LTD

E 210918

55-1 BUNSU 3-RI KWANGTAN-MYUN PAJU KYONGGI-DO
413-850, KOREA

Mtl Dsg	Mark Dsg	Coat type BC	Overcoat	ANSI Typ(+)	
DSUEW-100	(1)	Polyurethane	-	MW75C	130
UEW	(1)	polyurethane	None	MW79	155
				MW75	130(2)
PEW	(1)	Polyester	None	MW30	180
				MW5	155(2)

(1) Marked designations are the same as the material designations.

(2) Additional consideration is needed before its use in System's thermal aging.

Marking : Company name, material designation or marked designation on package or reel, and Recognized Component Mark.

NAMSUN ELECTRONICS CO., LTD.

Na-3506, Chungang Circulation Complex, 1258
Kurobon-dong, Kuro-Ku, Seoul, Korea, 152-721
TEL:02-2689-9418 , FAX:02-2689-8628

DESIGN CHECK APPROVAL

개발실
추유섭
10.05.07

개발실
이상순
10.05.07

개발실
조한석
10.05.07

FILE NO.

NS - A05071

<h1 style="margin: 0;">APPROVAL SHEET</h1>	DATE	2010-05-07
	PAGE	7 / 9

CUSTOMER			
PART NAME	LINE FILTER	MODEL NO.	NSV-202
PART NO.	UU1014-2mH-V	SIZE NO.	UU 1014 - V

BAKELITE AG E 61040 (M)
 POSTFACH 7154 58609, ISERLOHN-LETMATH FED
 REP GERMANY

Phenolic molding compound(PF), desingnated "Rutaform" or "furnished in the form of pellets or powder

PF2836@	BK	1.50	94V-0	150	150	150	0	2	~	5	~
PF2736@	NC,GN	0.81	94V-0	150	150	150	0	2	~	5	~
	BK										
	ALL	0.81	94V-1	150	150	150	0	2	~	5	~
	ALL	1.50	94V-0	150	150	150	0	2	0	~	~
		3.00	94V-0	150	150	150	0	2	0	5	
PF2560@	ALL	1.50	94V-1	150	150	150	~	~	~	~	~
	BK,NC	1.50	94V-0	150	150	150	~	~	~	~	~
	ALL	3.00	94V-0	150	150	150	~	~	~	~	~
PF31@	ALL	1.50	94V-1	150	150	150	1	1	~	6	~
		3.00	94V-0	150	150	150	0	1	~	~	~
PF2744@	ALL	1.50	94V-0	150	150	150	0	1	~	5	~
PF2855@	ALL	3.00	94V-0	150	150	150	0	3	~	5	~
PF6506@	ALL	1.50	94V-0	150	150	150	0	2	~	5	~

<p style="color: blue; font-weight: bold; margin: 0;"><i>NAMSUN ELECTRONICS CO., LTD.</i></p> <p style="margin: 5px 0;">Na-3506, Chungang Circulation Complex, 1258 Kurobon-dong, Kuro-Ku, Seoul, Korea, 152-721 TEL:02-2689-9418 , FAX:02-2689-8628</p>	DESIGN	CHECK	APPROVAL
			
	FILE NO.	NS - A05071	

<h1>APPROVAL SHEET</h1>	DATE	2010-05-07
	PAGE	8 / 9

CUSTOMER			
PART NAME	LINE FILTER	MODEL NO.	NSV-202
PART NO.	UU1014-2mH-V	SIZE NO.	UU 1014 - V

HYUN DAI CHEMICAL CO., LTD
 258 YEULMI-RI SILCHON-MYON KWANGJU
 KYONGGI-DO 464-870 KOREA

E 162848 (S)

Polyester tape with adhesive, cat. no. 800 for use at temperature not exceeding 190 c.
 Marking company name, catalog designation and temperature rating printed on carton, wrapper
 or core.

See General information preceding three recognitions

For use only equipment where the application is determined by underwriters
 Laboratories inc.

Report October 20, 1994.

1.06E+08 underwriters Laboratories inc. Dil/0264017

and Recognized Component Mark.

DUCK SUNG TAPE CO LTD
 DAESUNG BLDG 677 JAYANG-DONG SUNGDONG-KU,
 SEOUL 133-190 KOREA

E 105147 (S)

Polyester film insulating tape, cat. no. DTS-204 rated 130 C.

Acetate cloth insulating tape, cat. no. 231 rated 105 C.



Glass cloth insulating tape, cat. no. 220-B rated 130 C.

Acetate cloth insulating tape, cat. no. DTS-230 rated 105 C.

Marking: Company name or trademark or "E105147" and catalog designation
 printed on carton, wrapper or core.

NAMSUN ELECTRONICS CO., LTD.

Na-3506, Chungang Circulation Complex, 1258
 Kurobon-dong, Kuro-Ku, Seoul, Korea, 152-721
 TEL: 02-2689-9418 , FAX: 02-2689-8628

DESIGN	CHECK	APPROVAL
		
FILE NO.	NS - A05071	

APPROVAL SHEET

DATE 2010-05-07
PAGE 9 / 9

CUSTOMER			
PART NAME	LINE FILTER	MODEL NO.	NSV-202
PART NO.	UU1014-2mH-V	SIZE NO.	UU 1014 - V

ITEM NO	WIRE (130℃)	P.S TAPE (130℃)		
1	OK	OK		
2	"	"		
3	"	"		
4	"	"		
5	"	"		
6	"	"		
7	"	"		
8	"	"		
9	"	"		
10	"	"		

NAMSUN ELECTRONICS CO., LTD.

Na-3506, Chungang Circulation Complex, 1258
Kurobon-dong, Kuro-Ku, Seoul, Korea, 152-721
TEL: 02-2689-9418 , FAX: 02-2689-8628

DESIGN	CHECK	APPROVAL
개발실 추유섭 10.05.07	개발실 이상순 10.05.07	개발실 조한석 10.05.07
FILE NO.	NS - A05071	