

승 인	
정식승인	(        )
한도승인	(        )

# SPECIFICATIONS

CUSTOMER	
ITEM	LINE FILTER
MODEL NAME	NSV-103
PART No	UU1014-10mH-V-TYPE
DATE	2010-05-07

검 토	심 사	승 인
승인유효기간	승인일로부터	년

신청회사명	 <b>NAMSUN ELECTRONICS CO., LTD.</b>	TEL	02-2689-9418
		FAX	02-2689-8628
주 소	Na-3506, CHUNG ANG CIRCULATION COMPLEX 15 GYUNGINRO 53-GIL GURO-GU, SEOUL 08217, KOREA		
Homepage : <a href="http://www.nsn.co.kr">http://www.nsn.co.kr</a> / E-mail : <a href="mailto:sun@nsn.co.kr">sun@nsn.co.kr</a>			

# 개 정 이 력

CUSTOMER				MODEL NO	NSV-103
PART NO		UU1014-10mH-V		ITEM	LINE FILTER
NO	DATA	Page	개 정 항 목	개 정 사 유	확인
1	2010-05-07			초도발행	
2					
3					
4					
5					
6					
7					
8					
9					
10					
11					
12					
13					
14					



**NAMSUN ELECTRONICS CO., LTD.**

Na-3506, CHUNG ANG CIRCULATION COMPLEX 15  
GYUNGINRO 53-GIL GURO-GU, SEOUL 08217, KOREA

DESIGN

개발실  
추유섭  
10.05.07

FILE NO.

CHECK

개발실  
이상순  
10.05.07

APPROVAL

개발실  
조한석  
10.05.07

NS - A05071

# APPROVAL SHEET

DATE 2010-05-07  
PAGE 1 / 5

CUSTOMER			
PART NAME	LINE FILTER	MODEL NO.	NSV-103
PART NO.	UU1014-10mH-V	SIZE NO.	UU 1014 - V

## 1. DIMENSION (UNIT:mm)

< TOP VIEW >

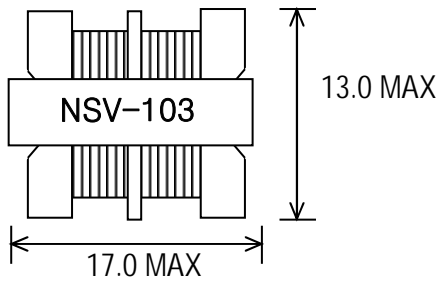

코어 조립 전 PS TAPE 1T 절연작업

< FRONT VIEW >

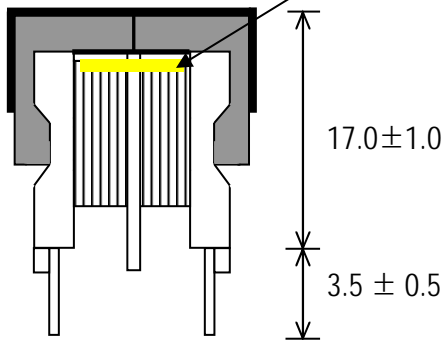

< SIDE VIEW >

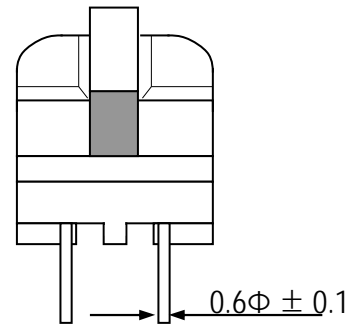

< BOTTOM VIEW >

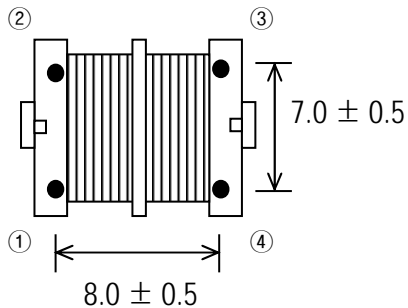

**\*주의사항\***

1. 코어 조립 전 P/S TAPE 1T 절연할것.



**NAMSUN ELECTRONICS CO., LTD.**

Na-3506, CHUNG ANG CIRCULATION COMPLEX 15  
GYUNGINRO 53-GIL GURO-Gu, SEOUL 08217, KOREA  
TEL:02-2689-9418 , FAX:02-2689-8628

DESIGN	CHECK	APPROVAL
개발실 추유섭 10.05.07	개발실 이상순 10.05.07	개발실 조한석 10.05.07
FILE NO.	NS - A05071	

# APPROVAL SHEET

DATE 2010-05-07

PAGE 2 / 5

CUSTOMER

PART NAME

LINE FILTER

MODEL NO.

NSV-103

PART NO.

UU1014-10mH-V

SIZE NO.

UU 1014 - V

## 2. SCHEMATIC DIAGRAM

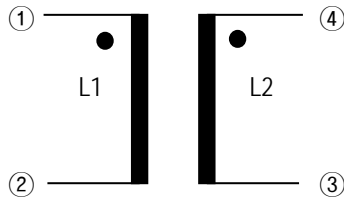

WINDNG

BOTTOM VIEW

C.C.W

BOBBIN INSERT

PRI SIDE(#1 ~ #2)

REMOVE PIN

## 3. WINDING SPECIFICATION

WINDING ORDER	COIL	TERMINAL (S - F)	WIRE	URNS (Ts)	WINDING METHOD
1	L1	1 - 2	2 UEW $\phi$ 0.24 ( AWG # )	90 $\pm$ 2T	SOLENOID WINDING
2	L2	4 - 3			SOLENOID WINDING

## 4. ELECTRICAL CHARACTERISTICS

NO	CLOSURE	TERMINAL NO.	SPECIFICATION	CONDITION
1	INDUCTANCE	1 - 2	10mH MIN	LCR METER UC2878B-UCE at 1kHz,1Vrms. (25°C) [Ls MODE]
2	DC RESISTANCE	1 - 2	$\Omega$ MAX $\Omega$ MAX	$\Omega$ METER UC2517B-UCE
3	WITHSTANDING VOLTAGE	COIL - CORE	AC 1,000 Vrms, 1 MINUTE.	KIKUSUI : TOS-5050 Cut off CURRENT (10mA)
4	INSULATION RESISTANCE	COIL - CORE	DC 500V, 100M $\Omega$ MIN.	MEGOHM METER (SM-5E)

 Na-3506, CHUNG ANG CIRCULATION COMPLEX 15  
 GYUNGINRO 53-GIL GURO-Gu, SEOUL 08217, KOREA  
 TEL:02-2689-9418 , FAX:02-2689-8628

DESIGN

CHECK

APPROVAL

 개발실  
 추유섭  
 10.05.07

 개발실  
 이상순  
 10.05.07

 개발실  
 조한석  
 10.05.07

FILE NO.

NS - A05071

# APPROVAL SHEET

DATE 2010-05-07  
PAGE 3 / 5

CUSTOMER			
PART NAME	LINE FILTER	MODEL NO.	NSV-103
PART NO.	UU1014-10mH-V	SIZE NO.	UU 1014 - V

## 5. ELECTRICAL CHARACTERISTICS

NO	ITEM	TERMINAL	SPECIFICATION	REMARKS
1	INDUCTANCE	L1 ( 1 - 2 )	10 mH MIN	LCR - METER UC2878B-UCE at 1.0 KHz. 1.0Vrms ( 25 °C ) [Ls MODE]
		L2 ( 4 - 3 )		
3	DC RESISTANCE	L1 ( 1 - 2 )	ohm MAX	Ω METER UC2517B-UCE
		L2 ( 4 - 3 )		
4	WITHSTNDING VOTAGE	COIL - COIL	AC 1,000 Vrms 1 MINUTE —	KIKSSI : TOS-5050 Cut off CURRENT (10mA)
5	INSULATION RESISTANCE	COIL - COIL	DC 500V, 100MΩ MIN	MEGOHM METER(SM-5E)

 **NAMSUN ELECTRONICS CO., LTD.**

Na-3506, CHUNG ANG CIRCULATION COMPLEX 15  
GYUNGINRO 53-GIL GURO-Gu, SEOUL 08217, KOREA  
TEL:02-2689-9418 , FAX:02-2689-8628

DESIGN

개발실  
추유섭  
10.05.07

FILE NO.

CHECK

개발실  
이상순  
10.05.07

APPROVAL

개발실  
조한석  
10.05.07

NS - A05071

# APPROVAL SHEET

DATE 2010-05-07  
PAGE 4 / 5

CUSTOMER			
PART NAME	LINE FILTER	MODEL NO.	NSV-103
PART NO.	UU1014-10mH-V	SIZE NO.	UU 1014 - V

## 6. SECTION DIAGRAM

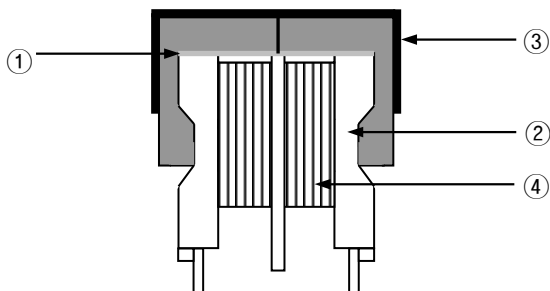

## 7. MATERIAL LIST

NO	COMPONENT	NAME OF MATERIAL	MANUFACTURER OF MATERIAL	REMARKS
1	CORE	UU1014 SM120 UU1014 R12K UU1014 R12K UU1014 R12K	SAMWHA ELECTRONICS CO., LTD. NANTONG GUANYOUDA AGNETIC., LTD. SHANGHAI JISHUN MAGNETIC MATERIAL HENGDIAN GROUP DMEGC MAGNETICS	
2	BOBBIN	PHENOLIC 94V-0 UU1014 "V"TYPE 4 PIN (2+2)	HEXION GMBH (PF2736(a)(b)) CHANG CHUN PLASTICS CO., LTD. (T375HF)	E61040 E59481
3	SPRING HOLDER	STAINLESS STEEL SUS 31	DAIYANG METAL CO.,LTD. (MAKER : HWASEUNG,WOOJIN)	
4	WIRE	2UEW $\phi$ 0.24	YANTAI ROME ELECTRONIC CO.,LTD. (UEW MW75-C) CNI Electronics Co Ltd (UEW MW75-C) ZHEJIANG HONGBO TECHNOLOGY (xUEW/130, QA-x/130,xUEW@/130,	E166187 E210918 E221719
5	INSULATION TAPE	POLYESTER FILM TAPE 0.025T*3.0mm	HYUNDAI CHEMICAL CO.,LTD. DUCKSUNG TAPE CO.,LTD.	E511186 E165111
6	VARNISH	R-831-* T-4260	ZHEJIANG RONGTAI TECHNICAL INDUSTRY CO., LTD. SUZHOU TAIHU ELECTRIC ADVANCED MATERIAL CO., LTD.	E227128 E228349
7	SOLDER	BAR, WIRE SN99.5% , CU0.5%	LT MATERIAL CO., LTD. ALPHA METAL	
	FLUX	LF-715K	DUIYUAN TECH(HUIZHOU) CO., LTD.	
8	MARKING	INK(BLACK)	HITACHI CHEMICAL CO.,LTD. BON MARQUE. MONAMI.	

 **NAMSUN ELECTRONICS CO., LTD.**

Na-3506, CHUNG ANG CIRCULATION COMPLEX 15  
GYUNGINRO 53-GIL GURO-Gu, SEOUL 08217, KOREA  
TEL:02-2689-9418 , FAX:02-2689-8628

DESIGN

개발실  
추유섭  
10.05.07

FILE NO.

CHECK

개발실  
이상순  
10.05.07

APPROVAL

개발실  
조한석  
10.05.07

NS - A05071

# APPROVAL SHEET

DATE 2010-05-07  
PAGE 5 / 5

CUSTOMER			
PART NAME	LINE FILTER	MODEL NO.	NSV-103
PART NO.	UU1014-10mH-V	SIZE NO.	UU 1014 - V

ITEM NO	WIRE (130℃)	P.S TAPE (130℃)		
1	OK	OK		
2	"	"		
3	"	"		
4	"	"		
5	"	"		
6	"	"		
7	"	"		
8	"	"		
9	"	"		
10	"	"		

 **NAMSUN ELECTRONICS CO., LTD.**

Na-3506, CHUNG ANG CIRCULATION COMPLEX 15  
GYUNGINRO 53-GIL GURO-Gu, SEOUL 08217, KOREA  
TEL:02-2689-9418 , FAX:02-2689-8628

DESIGN	CHECK	APPROVAL
개발실 추유섭 10.05.07	개발실 이상순 10.05.07	개발실 조한석 10.05.07
FILE NO.	NS - A05071	