

승 인	
정식승인	()
한도승인	()

SPECIFICATIONS

CUSTOMER	
ITEM	LINE FILTER
MODEL NAME	NSH-202
PART No	UU1014-2mH (H-TYPE)
DATE	2010-5-7

검 토	심 사	승 인
승인유효기간	승인일로부터	년

신청회사명	 남선전자주식회사	TEL	02-2689-9418
		FAX	02-2689-8628
주 소	Na-3506, Chungang Circulation Complex, 1258 Kurobon-dong, Kuro-Ku, Seoul, Korea, 152-721		

개 정 이 력

CUSTOMER				MODEL NO	NSH-202
PART NO		UU1014-2mH (H-TYPE)		ITEM	LINE FILTER
NO	DATA	Page	개 정 항 목	개 정 사 유	확인
1	2010. 05.07.			초도발행	
2					
3					
4					
5					
6					
7					
8					
9					
10					
11					
12					
13					
14					



Na-3506, Chungang Circulation Complex, 1258
 Kurobon-dong, Kuro-Ku, Seoul, Korea, 152-721
 TEL:02-2689-9418 , FAX:02-2689-8628

DESIGN	CHECK	APPROVAL
개발실 이상순 10.05.07	개발실 이기훈 10.05.07	개발실 노성복 10.05.07
FILE NO.	SH - 091028 - 71	

APPROVAL SHEET

DATE 2010-05-07

PAGE 1 / 5

CUSTOMER			
PART NAME	LINE FILTER	MODEL NO.	NSH-202
PART NO.	UU1014-2mH (H-TYPE)	SIZE NO.	UU 1014 (H)

1. APPEARANCE & DIMENSION

1) TOP VIEW

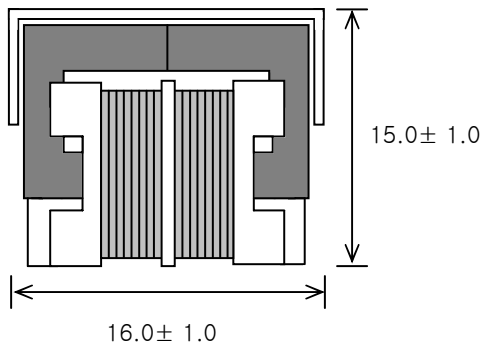

2) FRONT VIEW

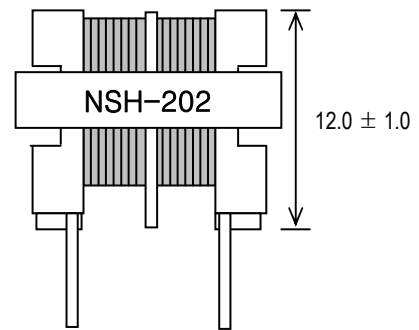

3) SIDE VIEW

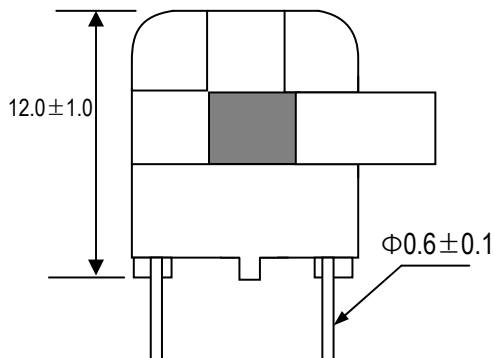

4) BOTTOM VIEW

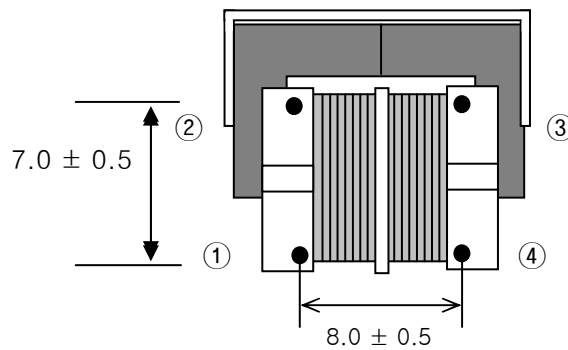

NAMSUN ELECTRONICS CO., LTD.

Na-3506, Chungang Circulation Complex, 1258
Kurobon-dong, Kuro-Ku, Seoul, Korea, 152-721
TEL: 02-2689-9418, FAX: 02-2689-8628

DESIGN

CHECK

APPROVAL

개발실
이상순
10.05.07

개발실
이기훈
10.05.07

개발실
노성복
10.05.07

FILE NO.

SH - 091028 - 71

APPROVAL SHEET

DATE 2010-05-07

PAGE 2 / 5

CUSTOMER

PART NAME

LINE FILTER

MODEL NO.

NSH-202

PART NO.

UU1014-2mH (H-TYPE)

SIZE NO.

UU 1014 (H)

2. SCHEMATIC DIAGRAM (BOTTOM VIEW)

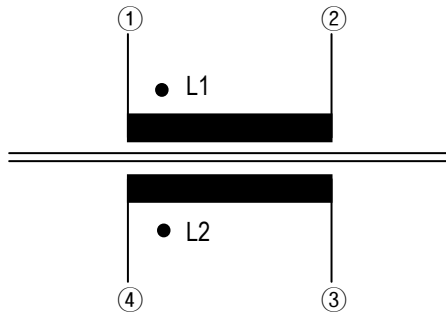

WINDNG	BOTTOM VIEW	C.C.W
N.C PIN		
REMOVE PIN		

3. WINDING SPECIFICATION

WINDING ORDER	NAME	TERMINAL	WIRE	TURNS	WINDING METHOD
1	L1	1 - 2	2UEW 0.32Φ	45T (Ref.)	SOLENOID WINDING
2	L2	4 - 3	2UEW 0.32Φ	45T (Ref.)	SOLENOID WINDING

4. ELECTRICAL CHARACTERISTICS

NO	CLOSURE	TERMINAL NO.	SPECIFICATION	CONDITION
1	INDUCTANCE	1 - 2	2mH MIN	HP-4284A at 1KHz, 1Vrms
2	DC RESISTANCE	1 - 2	Ω MAX Ω MAX	WHEATSTONE BRIDGE TAPE 2755, TYPE 3220
3	LAYER SHORT		AC 1.4KV, 1 MIN.	
4	DIELECTRIC STRENGTH	L1 - L2 COIL - CORE	AC1.5KV, 10mA . 1 MIN.	KIKUSUI : TOS-5050 (CURRENT SENSITIVE:5mA)
5	INSULATION RESISTANCE		100 Mohm MIN at DC 500V	MEGOHM METER (SM-5E)

 **NAMSUN ELECTRONICS CO., LTD.**

Na-3506, Chungang Circulation Complex, 1258
Kurobon-dong, Kuro-Ku, Seoul, Korea, 152-721
TEL:02-2689-9418 , FAX:02-2689-8628

DESIGN

CHECK

APPROVAL

개발실
이상순
10.05.07

개발실
이기훈
10.05.07

개발실
노성복
10.05.07

FILE NO.

SH - 091028 - 71

APPROVAL SHEET

DATE

2010-05-07

CUSTOMER			
PART NAME	LINE FILTER	MODEL NO.	NSH-202
PART NO.	UU1014-2mH (H-TYPE)	SIZE NO.	UU 1014 (H)

5. CONSTRUCTION

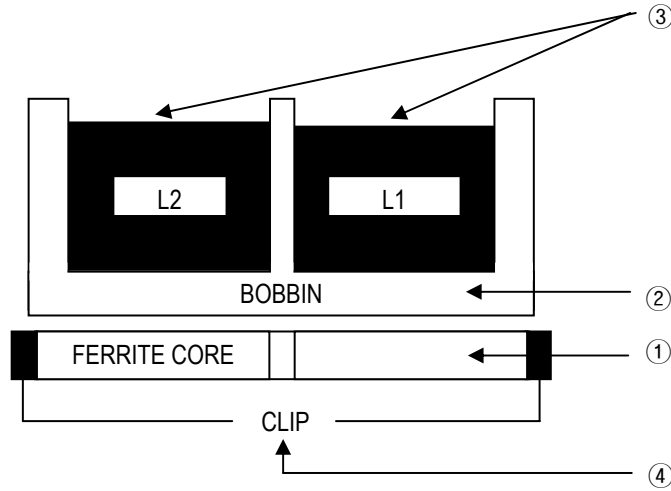

6. MATERIAL LIST

NO	COMPONENT	NAME OF MATERIAL	MANUFACTURER OF MATERIAL	REMARKS
1	CORE	UU 1014 (HM3B) UU 1014 (SM-70) UU 1014 (R10K)	ISU CO.,LTD. SAMHWA ELECTRONICS CO.,LTD. DMEGC MAGNETICS CO.,LTD.	
2	BOBBIN	PHENOLIC 94V-0 [UU 1014 4P V-TYPE]	BAKELITE GESELLSCHAFT MBH	E61040(M)
3	WIRE	POLYURETHANE 2UEW 0.30Φ	TAIHAN ELECTRIC WIRE CO., LTD. CNI CABLE CO.,LTD. NAMHAE ELECTRONICS CO.,LTD.	E109312(N) E210918
4	CLIP	STAINLESS STEEL	DAEHYUN INDUSTRIAL JINWON BOBBIN.	
5	VARNISH	SR - 337	SE GYE CHEMICAL CO.,LTD.	
6	FLUX	LF - 715K	TAEWON CHEMICAL CO.,LTD.	
7	SOLDER	SN99.5%,CU0.5%	DONGBU HANNONG CHEMICAL CO.,LTD.	



Na-3506, Chungang Circulation Complex, 1258
Kurobon-dong, Kuro-Ku, Seoul, Korea, 152-721
TEL:02-2689-9418 , FAX:02-2689-8628

DESIGN	CHECK	APPROVAL
개발실 이상순 10.05.07	개발실 이기훈 10.05.07	개발실 노성복 10.05.07
FILE NO.	SH - 091028 - 71	

APPROVAL SHEET

PAGE

4 / 5

CUSTOMER			
PART NAME	LINE FILTER	MODEL NO.	NSH-202
PART NO.	UU1014-2mH (H-TYPE)	SIZE NO.	UU 1014 (H)

7. UL LIST

BAKELITE AG

E 61040 (M)

POSTFACH 7154 58609, ISERLOHN-LETMATH FED
REP GERMANY

Phenolic molding compound(PF), desingnated "Rutaform" or "furnished in the form of pellets or powder

PF2836@	BK	1.50	94V-0	150	150	150	0	2	~	5	~
● PF2736@	NC,GN	0.81	94V-0	150	150	150	0	2	~	5	~
	BK										
	ALL	0.81	94V-1	150	150	150	0	2	~	5	~
	ALL	1.50	94V-0	150	150	150	0	2	0	~	~
		3.00	94V-0	150	150	150	0	2	0	5	
PF2560@	ALL	1.50	94V-1	150	150	150	~	~	~	~	~
	BK,NC	1.50	94V-0	150	150	150	~	~	~	~	~
	ALL	3.00	94V-0	150	150	150	~	~	~	~	~
PF31@	ALL	1.50	94V-1	150	150	150	1	1	~	6	~
		3.00	94V-0	150	150	150	0	1	~	~	~
PF2744@	ALL	1.50	94V-0	150	150	150	0	1	~	5	~
PF2855@	ALL	3.00	94V-0	150	150	150	0	3	~	5	~
PF6506@	ALL	1.50	94V-0	150	150	150	0	2	~	5	~



Na-3506, Chungang Circulation Complex, 1258
Kurobon-dong, Kuro-Ku, Seoul, Korea, 152-721
TEL:02-2689-9418 , FAX:02-2689-8628

DESIGN	CHECK	APPROVAL
개발실 이상순 10.05.07	개발실 이기훈 10.05.07	개발실 노성복 10.05.07
FILE NO.	SH - 091028 - 71	

APPROVAL SHEET

DATE

2010-05-07

APPROVAL SHEET

PAGE

5 / 5

CUSTOMER			
PART NAME	LINE FILTER	MODEL NO.	NSH-202
PART NO.	UU1014-2mH (H-TYPE)	SIZE NO.	UU 1014 (H)

TAIHAN ELECTRIC WIRE CO., LTD.

E 109312 (N)

194-15 1-KA HOEHYUN-DONG CHUNG-KU CPO
BOX 2624, SEOUL KOREA

Mti Dsg	Coat type BC	Overcoat	ANSI Type	T1
Magnet wire.				
EI-AIW	Ester-imide imide	Polyamide- imide	MW35.73	200
AL EI-AIW	Ester-imide	Polyamide- imide	MW35	240
EIW	Ester-imide	-	MW30.72	180
EIW-N	Ester-imide	Polyamide	MW76	180
AIW	Polyamide-imide	-	-	220
PEW-N	Polyester	Polyamide	MW76	180
SEIW	Solderable Polyester-imide	-	MW77	180
● UEW	Polyurethane	-	MW75	130
UEW-N	Polyurethane	Polyamide	MW80	155

Reports : April 2, 1987; April 2, 1987; April 2, 1987; April 2, 1987: April 2, 1987; April 2, 1987; April 2, 1987; April 2, 1987; April 2, 1987; April 2, 1987.

CNI CABLE CO.,LTD

E 210918

312-16, DEUKSAN-DONG,
ASAN-SI, GYEONGGI-DO, 336-120, REPUBLIC OF KOREA

Mti Dsg	Mark Dsg	Coat Type		ANSI Type	Temp Class
		BC	OC		
● DSUEW-100	(1)	Polyurethane	-	MW75C	130#
UEW	(1)	Polyurethane	None	MW79	155
				MW75	130#
PEW	(1)	Polyester	None	MW30	180
				MW5	155#

(1) Marked designations are the same as the material designations.

- This wire may perform better than its temperature rating reflects. Hence, It may not be suitable to use in an insulation system thermal aging program.



Na-3506, Chungang Circulation Complex, 1258
Kurobon-dong, Kuro-Ku, Seoul, Korea, 152-721
TEL:02-2689-9418 , FAX:02-2689-8628

DESIGN	CHECK	APPROVAL
FILE NO.	SH - 091028 - 71	