

승 인	
정식승인	()
한도승인	()

SPECIFICATIONS

CUSTOMER	
ITEM	LINE FILTER
MODEL NAME	
PART No	Φ25 x 1mH(BASE A-TYPE)
DATE	2009-06-15

검 토	심 사	승 인
승인유효기간	승인일로부터	년

신청회사명	 남선전자주식회사	TEL	02-2689-9418
		FAX	02-2689-8628
주 소	Na-3506, Chungang Circulation Complex, 1258 Kurobon-dong, Kuro-Ku, Seoul, Korea, 152-721		

APPROVAL SHEET

DATE

2009-06-15

PAGE

1 / 3

CUSTOMER

PART NAME

LINE FILTER

MODEL NO.

PART NO.

Φ25 * 1mH(BASE A-TYPE)

SIZE NO.

T2512

1. DIMENSION (UNIT:mm)

<TOP VIEW>

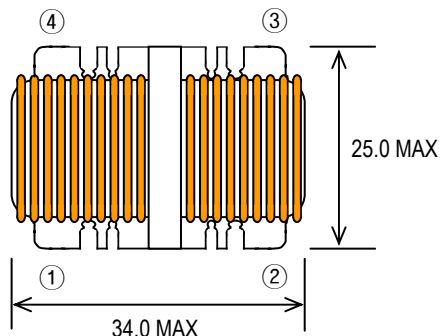

<FRONT VIEW>

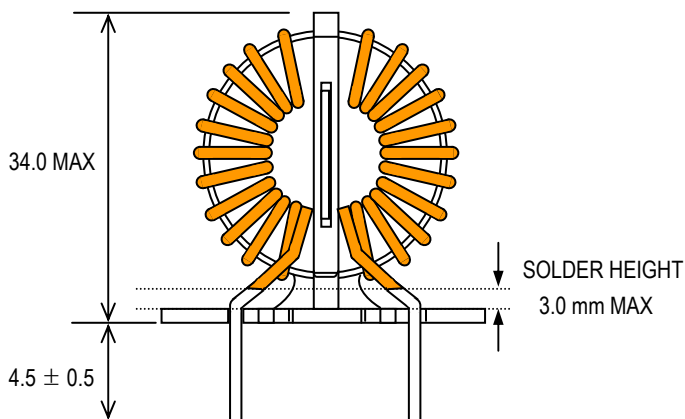

<SIDE VIEW>

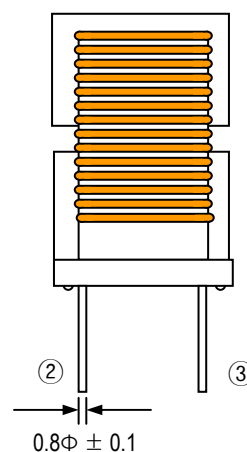

<BOTTOM VIEW>

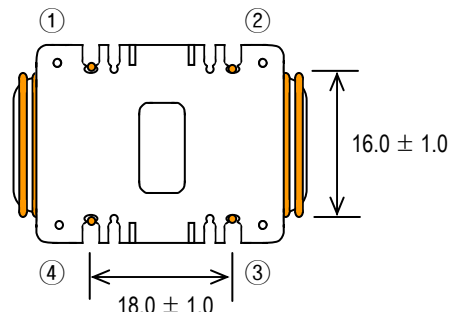

NAMSUN ELECTRONICS CO., LTD.

Na-3506, Chungang Circulation Complex, 1258
Kurobon-dong, Kuro-Ku, Seoul, Korea, 152-721
TEL: 02-2689-9418, FAX: 02-2689-8628

DESIGN

CHECK

APPROVAL

개발실

개발실

개발실

이상순

김상문

조한석

09.06.15

09.06.15

09.06.15

FILE NO.

SH - 080813 - 05

APPROVAL SHEET

DATE	2009-06-15
PAGE	2 / 3

CUSTOMER			
PART NAME	LINE FILTER	MODEL NO.	
PART NO.	Φ25 * 1mH(BASE A-TYPE)	SIZE NO.	T2512

2. SCHEMATIC DIAGRAM

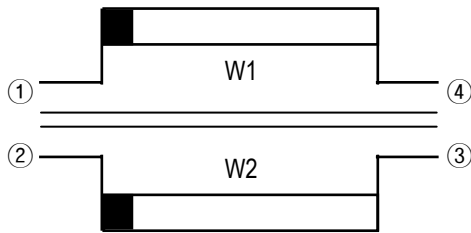

WINDNG	BOTTOM VIEW	C.C.W
N.C PIN		
REMOVE PIN		

3. WINDING SPEC

WINDING ORDER	TERMINAC NO	WIRE	TURNS
W1	1 → 4	UEW 1.2Φ x 1P	12Ts
W2	2 → 3	UEW 1.2Φ x 1P	12Ts

4. ELECTRICAL CHARACTERISTIC

NO	CLOSURE	TERMINAL NO.	ELECTRICAL CHARACTERISTICS	TOLERANCE	CONDITION
1	INDUCTANCE	1 → 4 2 → 3	1.0 mH	+ 25 -25%	PM - 6306 LCR-METER at 1.0 KHz. LEVEL : 1.0V
2	DC CURRENT OVERLAP	DC 0.5mA, (START TO FINISH)			
3	INSULATION RESISTANCE	DC 500V, 100MΩ MIN(COIL TO CORE)			

NAMSUN ELECTRONICS CO., LTD.

Na-3506, Chungang Circulation Complex, 1258
 Kurobon-dong, Kuro-Ku, Seoul, Korea, 152-721
 TEL: 02-2689-9418 , FAX: 02-2689-8628

DESIGN	CHECK	APPROVAL
 이상순 09.06.15	 김상문 09.06.15	 조한석 09.06.15
FILE NO.	SH - 080813 - 05	

APPROVAL SHEET

DATE 2009-06-15
PAGE 3 / 3

CUSTOMER			
PART NAME	LINE FILTER	MODEL NO.	
PART NO.	Φ25 * 1mH(BASE A-TYPE)	SIZE NO.	T2512

5. INTERNAL STRUCTURE

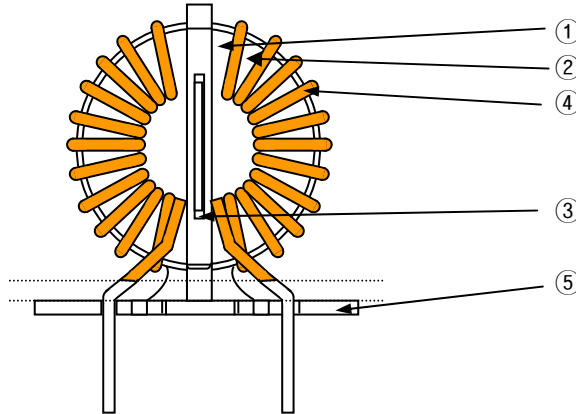

6. MATERIAL LIST

NO	COMPONENT	NAME OF MATERIAL	MANUFACTURER OF MATERIAL	REMARKS
1	CORE	HM5A T2512	ISU CO.,LTD.	
2	CORE COVER	PBT (SK655FR) PBT (GP-1006-F) PBT (VB-5300GF) UL94V-0 CLASS	EI DUPONT DE NEMOURS & CO.,LTD LG CHEMICAL LTD CHEIL INDUSTRIES INC.	E41938 E67171(M) E115797
3	COIL SEPARATOR	PBT (SK655FR) PBT (GP-2306-F) PBT (VB-5300GF) UL94V-0 CLASS	EI DUPONT DE NEMOURS & CO.,LTD LG CHEMICAL LTD CHEIL INDUSTRIES INC.	E41938 E67171(M) E115797
4	WIRE	POLYURETHANE UEW 0.8Φ	TAIHAN ELECTRIC WIRE CO., LTD. CNI CABLE CO.,LTD.	E109312(N) E210918
5	BASE	PBT (SK655FR) PBT (VB-5300GF) PHENOLIC (PF2736) 94V-0	EI DUPONT DE NEMOURS & CO.,LTD CHEIL INDUSTRIES INC. BAKELITE GESELLSCHAFT MBH	E41938 E115797 E61040 (M)
6	FLUX	LF - 715K	TAEWON CHEMICAL CO., LTD.	
7	SOLDER	SN99.5%,CU0.5%	DONGBU HANNONG CHEMICAL CO.,LTD.	

NAMSUN ELECTRONICS CO., LTD.

Na-3506, Chungang Circulation Complex, 1258
Kurobon-dong, Kuro-Ku, Seoul, Korea, 152-721
TEL:02-2689-9418 , FAX:02-2689-8628

DESIGN	CHECK	APPROVAL
개발실 이상순 09.06.15	개발실 김상문 09.06.15	개발실 조한석 09.06.15
FILE NO.	SH - 080813 - 05	