

승 인	
정식승인	(        )
한도승인	(        )

# SPECIFICATIONS

CUSTOMER	
ITEM	LINE FILTER
MODEL NAME	
PART No	Φ14 *1mH*BASE "B"-TYPE
DATE	2013-07-15

검 토	심 사	승 인
승인유효기간	승인일로부터	년

신청회사명	 <b>남선전자주식회사</b>	TEL	02-2689-9418
		FAX	02-2689-8628
주 소	Na-3506, Chungang Circulation Complex, 1258 Kurobon-dong, Kuro-Ku, Seoul, Korea, 152-721		

# 개정이력 LIST

REV NO.	개정일자	개정항목	개정내용	관련근거
0	2013-07-15		초도발행	
1				
2				
3				
4				
5				
6				
7				
8				
9				
10				
11				
12				
13				
14				
15				

# APPROVAL SHEET

DATE

2013-07-15

PAGE

1 / 7

CUSTOMER

PART NAME

LINE FILTER

MODEL NO.

PART NO.

Φ14 \*1mH\*BASE B"-TYPE

SIZE NO.

T1407

1. DIMENSION (UNIT:mm)

<SIDE VIEW>

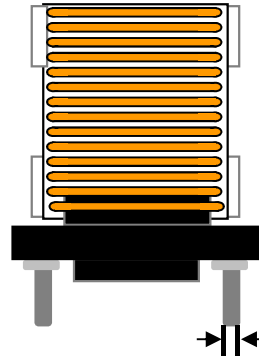

0.75 ± 0.05

<FRONT VIEW>

20m/m max

25m/m max

3.7 ±

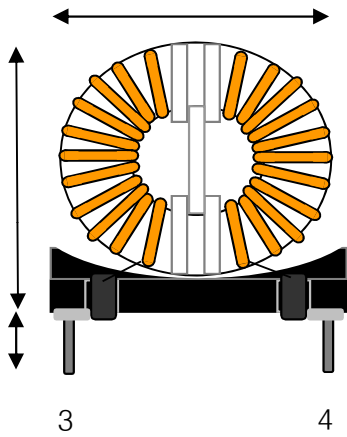

3

4

<BOTTOM VIEW>

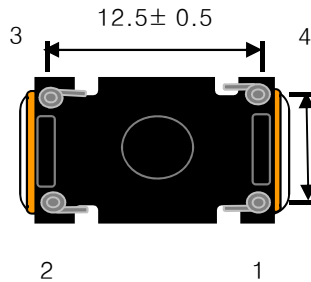

3

12.5 ± 0.5

4

10.0 ± 0.5

2

1

**NAMSUN ELECTRONICS CO., LTD.**

Na-3506, Chungang Circulation Complex, 1258  
Kurobon-dong, Kuro-Ku, Seoul, Korea, 152-721  
TEL:02-2689-9418 , FAX:02-2689-8628

DESIGN

CHECK

APPROVAL

개발실  
마태규  
13-7-15

개발실  
김상문  
13-7-15

개발실  
조한석  
13-7-15

FILE NO.

# APPROVAL SHEET

DATE 2013-07-15

PAGE 2 / 7

CUSTOMER

PART NAME

LINE FILTER

MODEL NO.

PART NO.

Φ14 \*1mH\*BASE B"-TYPE

SIZE NO.

T1407

## 2. SCHEMATIC DIAGRAM

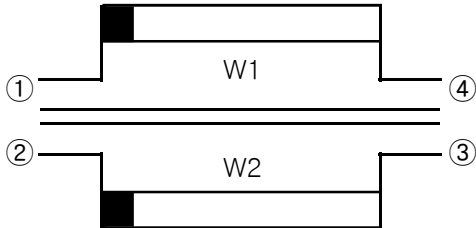

WINDNG

BOTTOM VIEW

C.C.W

N.C PIN

REMOVE PIN

## 3. WINDING SPEC

WINDING ORDER	TERMINAC NO	WIRE	TURNS
W1	1 → 4	2UEW 0.6Φ x 1P	16 Ts
W2	2 → 3	2UEW 0.6Φ x 1P	16 Ts

## 4. ELECTRICAL CHARACTERISTIC

NO	CLOSURE	TERMINAL NO.	ELECTRICAL CHARACTERISTICS	TOLERANCE	CONDITION
1	INDUCTANCE	1 → 4 2 → 3	1.0 mH	± 25%	PM - 6306 LCR-METER at <u>1.0</u> KHz. LEVEL : <u>1.0</u> V
2	DC CURRENT OVERLAP	DC 0.5m A, (START TO FINISH)			
3	INSULATION RESISTANCE	DC 500V, 100MΩ MIN(COIL TO CORE)			

**NAMSUN ELECTRONICS CO., LTD.**

Na-3506, Chungang Circulation Complex, 1258  
Kurobon-dong, Kuro-Ku, Seoul, Korea, 152-721  
TEL:02-2689-9418 , FAX:02-2689-8628

DESIGN

CHECK

APPROVAL

개발실  
마태규  
13-7-15

개발실  
김상문  
13-7-15

개발실  
조한석  
13-7-15

FILE NO.

# APPROVAL SHEET

DATE 2013-07-15

PAGE 3 / 7

CUSTOMER

PART NAME

LINE FILTER

MODEL NO.

PART NO.

Φ14 \*1mH\*BASE B"-TYPE

SIZE NO.

T1407

## 5. INTERNAL STRUCTURE

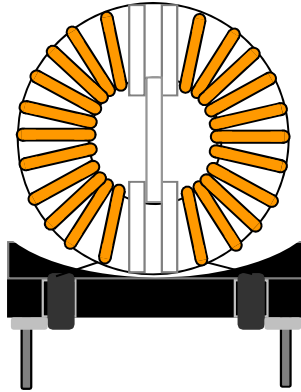

## 6. MATERIAL LIST

NO	COMPONENT	NAME OF MATERIAL	MANUFACTURER OF MATERIAL	REMARKS
1	CORE	HM5A T1407	ISU CO.,LTD.	
2	CORE COVER	PBT (SK655FR) PBT (GP-1006-F) PBT (VB-5300GF) UL94V-0 CLASS	EI DUPONT DE NEMOURS & CO.,LTD LG CHEMICAL LTD CHEIL INDUSTRIES INC.	E41938 E67171(M) E115797
3	COIL SEPARATOR	PBT (SK655FR) PBT (GP-2306-F) PBT (VB-5300GF) UL94V-0 CLASS	EI DUPONT DE NEMOURS & CO.,LTD LG CHEMICAL LTD CHEIL INDUSTRIES INC.	E41938 E67171(M) E115797
4	WIRE	POLYURETHANE 2UEW 0.6Φ	TAIHAN ELECTRIC WIRE CO., LTD. DONG YANG ELECTRONICS IND CO., LTD.	E109312(N) E210918
5	BASE	PBT (SK655FR) PBT (VB-5300GF) PHENOLIC (PF2736) 94V-0	EI DUPONT DE NEMOURS & CO.,LTD CHEIL INDUSTRIES INC. BAKELITE GESELLSCHAFT MBH	E41938 E115797 E61040 (M)
6	FLUX	LF - 715K	TAEWON CHEMICAL CO., LTD.	
7	SOLDER	SN99.5%,CU0.5%	DONGBU HANNONG CHEMICAL CO.,LTD.	

**NAMSUN ELECTRONICS CO., LTD.**

Na-3506, Chungang Circulation Complex, 1258  
Kurobon-dong, Kuro-Ku, Seoul, Korea, 152-721  
TEL:02-2689-9418 , FAX:02-2689-8628

DESIGN

CHECK

APPROVAL

개발실  
마태규  
13-7-15

개발실  
김상문  
13-7-15

개발실  
조한석  
13-7-15

FILE NO.

# APPROVAL SHEET

DATE 2013-07-15

PAGE 4 / 7

CUSTOMER

PART NAME

LINE FILTER

MODEL NO.

PART NO.

Φ14 \*1mH\*BASE B"-TYPE

SIZE NO.

T1407

## 8. UL LIST

QMFZ2

September 14, 2000

Plastics - Component

LG CHEMICAL LTD

E 67171 (M)

Material Dsg	Color	Min THK mm	Flame Class	H W	H A	Elec	R T I		H V	D 4	C
							Imp	Str			
		1.5	V-0	3	0	140	125	140	-	-	-
		3.0	V-0	2	0	140	125	140	2	6	3
● GP-1006-F	ALL	0.71	V-0	4	3	130	130	140	-	-	-
		1.5	V-0	3	0	130	130	140	-	-	-
		3.0	V-0	3	0	130	130	140	3	6	0
GP-1008F	ALL	0.74	V-0	4	0	75	75	75	-	-	-
		1.5	V-0	3	0	75	75	75	-	-	-
		3.0	V-0	2	0	75	75	75	0	6	1
GP-2(b)0	ALL	0.71	HB	-	-	140	120	140	-	-	-
		1.5	HB	4	0	140	120	140	-	-	-
		3.0	HB	3	0	140	120	140	0	5	0
GP-2(b)1-F	ALL	0.84	V-0	4	4	140	125	140	-	-	-
		1.5	V-0	3	0	140	125	140	-	-	-
		3.0	V-0	2	0	140	125	140	2	6	3
GP-2(b)6F	ALL	0.71	V-0	4	4	130	130	140	-	-	-

9/14/2000

Underwriters Laboratories Inc.

Card 35 of 60

QMFZ2

September 14, 2000

Plastics - Component

LG CHEMICAL LTD

E 67171 (M)

Material Dsg	Color	Min THK mm	Flame Class	H W	H A	Elec	R T I		H V	D 4	C
							Imp	Str			
GP-2300 (PBT)	ALL	0.71	HB	-	-	140	130	140	-	-	-
		1.5	HB	2	0	140	130	140	0	-	-
		3.3	HB	1	0	140	130	140	0	5	0
GP-2300 (PP)	ALL	0.71	HB	-	-	140	130	140	-	-	-
		1.5	HB	2	0	140	130	140	-	-	-
		3.0	HB	1	0	140	130	140	0	5	0
GP-2301-F	ALL	0.71	V-0	3	1	140	125	140	-	-	-
		1.5	V-0	2	0	140	125	140	-	-	-
		3.3	V-0	1	0	140	125	140	0	6	2
● GP-2306-F	ALL	0.75	V-0	4	1	140	140	140	-	-	-
		1.5	V-0	2	1	140	140	140	-	-	-
		3.0	V-0	0	0	140	140	140	3	6	2
GP-2308F	ALL	0.74	V-0	3	0	75	75	75	-	-	-

9/14/2000

Underwriters Laboratories Inc.

Card 37 of 60

 **NAMSUN ELECTRONICS CO., LTD.**

Na-3506, Chungang Circulation Complex, 1258  
Kurobon-dong, Kuro-Ku, Seoul, Korea, 152-721  
TEL: 02-2689-9418, FAX: 02-2689-8628

DESIGN

CHECK

APPROVAL

개발실

개발실

개발실

마태규

김상문

조한석

13-7-15

13-7-15

13-7-15

FILE NO.

# APPROVAL SHEET

DATE 2013-07-15

PAGE 5 / 7

CUSTOMER

PART NAME

LINE FILTER

MODEL NO.

PART NO.

Φ14 \*1mH\*BASE B"-TYPE

SIZE NO.

T1407

QMF22 Component - Plastics

Friday, November 21, 2003

E 4193B

E I DUPONT DE NEMOURS & CO INC

ENGINEERING POLYMERS CHESTNUT RUN PLAZA PO BOX 80713 WILMINGTON DE 19880

Material Designation: SK655FR (+)

Product Description Polybutylene Terephthalate (PBT), glass reinforced, flame retardant, designated "Crastln" fumlshed as pellets.

Color	Min.Thick.(mm)	Flame Class	HWI	HAI	RTI Elec	RTI Imp	RTI Str	IEC GWIT	IEC GWFI
ALL	0.75	V-0	3	0	130	130	140	-	-
	1.5	V-0	3	0	130	130	140	-	-
	3.0	V-0	2	0	130	130	140	-	-

QMFZ2

Tuesday, April 13, 1999

E 115797

Component - Plastics

CHEIL INDUSTRIES INC

CHEMICALS DIV R & D CENTER 332-2 GOCHUN-DONG EUIWANG-SHI  
KYONGGI-DO 437-010, KOREA

Material Designation : VB-5300G+

Product Description : (PBTP), furnished as pellets.

Color	Min. Thick. (mm)	Flame Class	HWI	HAI	RTI Elec	RTI Imp	RTI Str	IEC GWIT	IEC GWFI
ALL	0.75	V-0	4	1	130	120	130	-	-
	1.7	V-0	3	0	130	120	130	-	-
	3.0	V-0	2	0	130	120	140	-	-

CTI: 2

HVTR: 4

D495: 6

IEC BP: -

+ optional suffix.

Report Date: / /

Underwriters Laboratories Inc

2.81E+08

UL94 small-scale test data does not pertain to building materials, furnishings and related contents, UL94 small-scale test data is intended solely for determining the flammability of plastic materials used in components and parts of end-product devices and appliances, where the acceptability of the combination is determined by ULI.

 **NAMSUN ELECTRONICS CO., LTD.**

Na-3506, Chungang Circulation Complex, 1258  
Kurobon-dong, Kuro-Ku, Seoul, Korea, 152-721  
TEL:02-2689-9418 , FAX:02-2689-8628

DESIGN

CHECK

APPROVAL

개발실

개발실

개발실

마태규

김상문

조한석

13-7-15

13-7-15

13-7-15

FILE NO.

# APPROVAL SHEET

DATE 2013-07-15

PAGE 6 / 7

CUSTOMER

PART NAME

LINE FILTER

MODEL NO.

PART NO.

Φ14 \*1mH\*BASE B"-TYPE

SIZE NO.

T1407

DONG YANG ELECTRONICS IND CO., LTD.  
 5-20 BANGYE-RI  
 MUNMAK-EUB  
 WONJU-SHI, KANGWON-DO 220-800 REPUBLIC OF KOREA

Mtl Dsg	Coat type	Overcoat	ANSI Type	T1	
AI-EIW	Polyester imide	Polyamide-imide	MW35	##	
DSB-EIA	Ester-imide	Polyamideimide	MW76	180	
DSB-EIA(S)	Solderable ester-imide	Polyamideimide	MW78	180	
EIW	Polyester imide		MW30	180	
NY-EIW	Polyester-amide-imide	Polyamide	MW76	180	
NY-PEW	Polyester	Polyamide	MW24	155	
NY-PEW(F)	Polyester	Polyamide	MW24	155	
NY-U EW	Polyurethane	Polyamide	MW80, MW28#	155, 130	
UEW(F)	Polyurethane	-	MW79,	155,	
● UEW(B)	Polyurethane	-	MW75#	130	
UAL	Polyurethane	-	@	155	E 210918
PEW	Polyester		@	180	
			MW5#	155	

Note : UAL is the alternate aluminum grade designation of magnet wire designated uew. @ - Non-ANSI type.

#- The wire perform better than the rating reflects and hence may not be suitable for insulation system testing.

Marking : Company name or "E102761" and material designation or marked designation on package or reel.

Last Updated on 2007-01-08

 **NAMSUN ELECTRONICS CO., LTD.**

Na-3506, Chungang Circulation Complex, 1258  
 Kurobon-dong, Kuro-Ku, Seoul, Korea, 152-721  
 TEL:02-2689-9418 , FAX:02-2689-8628

DESIGN

CHECK

APPROVAL

개발실  
 마태규  
 13-7-15

개발실  
 김상문  
 13-7-15

개발실  
 조한석  
 13-7-15

FILE NO.



# APPROVAL SHEET

DATE 2013-07-15

PAGE 7 / 7

CUSTOMER

PART NAME

LINE FILTER

MODEL NO.

PART NO.

Φ14 \*1mH\*BASE B"-TYPE

SIZE NO.

T1407

TAIHAN ELECTRIC WIRE CO., LTD.  
194-15 1-KA HOEHYUN-DONG CHUNG-KU CPO  
BOX 2624, SEOUL KOREA

Mtl	Coat type		ANSI	
Dsg	BC	Overcoat	Type	T1
Magnet wire.				
EI-AIW	Ester-imide	Polyamide-imide	MW35.73	200
AL EI-AIW	Ester-imide	Polyamide-imide	MW35	240
EIW	Ester-imide	-	MW30.72	180
EIW-N	Ester-imide	Polyamide	MW76	180
AIW	Polyamide-imide	-	-	220
PEW-N	Polyester	Polyamide	MW76	180
SEIW	Solderable	-	MW77	180
	Polyester-imide			
● UEW	Polyurethane	-	MW75	130
UEW-N	Polyurethane	Polyamide	MW80	155

Reports : April 2, 1987; April 2, 1987; April 2, 1987; April 2, 1987; April 2, 1987; April 2, 1987; April 2, 1987; April 2, 1987; April 2, 1987; April 2, 1987.

 **NAMSUN ELECTRONICS CO., LTD.**

Na-3506, Chungang Circulation Complex, 1258  
Kurobon-dong, Kuro-Ku, Seoul, Korea, 152-721  
TEL:02-2689-9418 , FAX:02-2689-8628

DESIGN

CHECK

APPROVAL

개발실  
마태규  
13-7-15

개발실  
김상문  
13-7-15

개발실  
조한석  
13-7-15

FILE NO.