

승 인	
정식승인	()
한도승인	()

SPECIFICATIONS

CUSTOMER	
ITEM	LINE FILTER
MODEL NAME	
PART No	Φ10 x 2mH(H.B)
DATE	2008-06-02

검 토	심 사	승 인
승인유효기간	승인일로부터	년

신청회사명	 남선전자주식회사	TEL	02-2689-9418
		FAX	02-2689-8628
주 소	Na-3506, Chungang Circulation Complex, 1258 Kurobon-dong, Kuro-Ku, Seoul, Korea, 152-721		

<h1>SPECIFICATIONS</h1>		SHEET NO.	1 OF 7
		DATE	2008-06-02
PART NAME	LINE FILTER	MODEL NAME	
PART NO.	Φ10 x 2mH(H.B)	TYPE	T1004 (HM3A)

1. APPEARANCE & DIMENSION (m/m)

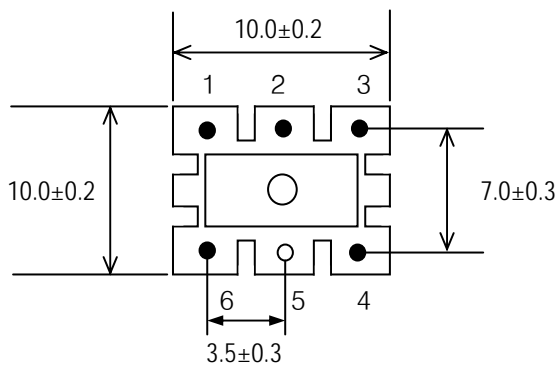
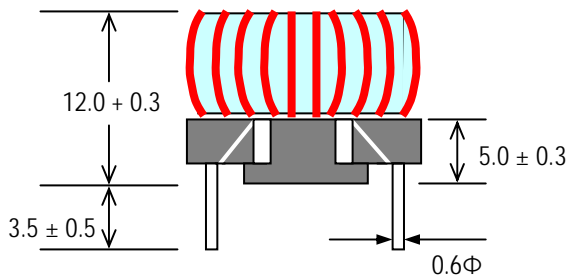
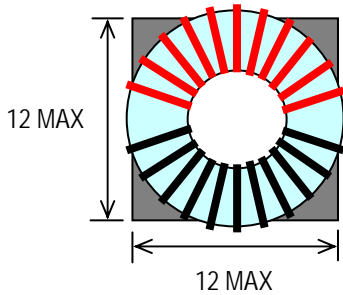

NAMSUN ELECTRONICS CO., LTD.

Na-3506, Chungang Circulation Complex, 1258
Kurobon-dong, Kuro-Ku, Seoul, Korea, 152-721
TEL: 02-2689-9418 , FAX: 02-2689-8628

DESIGN	CHECK	APPROVAL
개발실 김영라 08.06.02	개발실 이은숙 08.06.02	개발실 조한석 08.06.02
FILE NO.	SH - 060601 - 01	

<h1 style="margin: 0;">SPECIFICATIONS</h1>	SHEET NO.	2 OF 7
	DATE	2008-06-02

PART NAME	LINE FILTER	MODEL NAME	
PART NO.	Φ10 x 2mH(H.B)	TYPE	T1004 (HM3A)

2. SCHEMATIC DIAGRAM

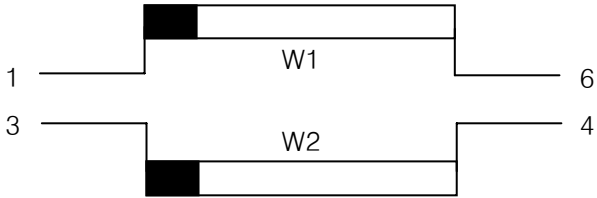

WINDNG	BOTTOM VIEW	C.C.W
REMOVE PIN	# 5	

3. WINDING SPEC

WINDING ORDER	TERMINAL NO	WIRE	TURNS	WINDING METHOD
W1	1 - 6	UEW 0.30 Φ	35 T	SOLENOID
W2	3 - 4	UEW 0.30 Φ	35 T	SOLENOID

4. ELECTRICAL CHARACTERISTIC

NO	CLOSURE	TERMINAL NO.	ELECTRICAL CHARACTERISTICS	TOLERANCE	CONDITION
1	INDUCTANCE	S - F	2.0 mH	MIN	LCR-745 LCR-METER at 1.0 KHz. LEVEL : 1.0V r.m.s (25 °C)

<p style="margin: 0;">Na-3506, Chungang Circulation Complex, 1258 Kurobon-dong, Kuro-Ku, Seoul, Korea, 152-721 TEL: 02-2689-9418 , FAX: 02-2689-8628</p>	DESIGN	CHECK	APPROVAL
	FILE NO.	SH - 060601 - 01	

<h1 style="margin: 0;">SPECIFICATIONS</h1>		SHEET NO.	3 OF 7
		DATE	2008-06-02
PART NAME	LINE FILTER	MODEL NAME	
PART NO.	Φ10 x 2mH(H.B)	TYPE	T1004 (HM3A)

5. INTERNAL STRUCTURE

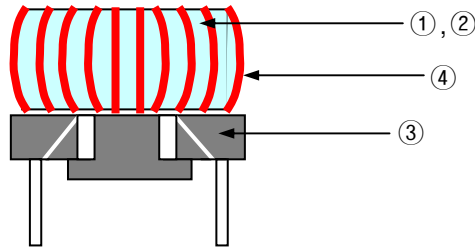

6. MATERIAL LIST

NO	COMPONENT	NAME OF MATERIAL	MANUFACTURER OF MATERIAL	REMARKS
1	CORE	T1004 HM3A	ISU CO., LTD.	
2	CORE COATING	EPOXY MC-306 (SKY BLUE)	MISUNG CHEMICAL CO.,LTD.	
3	BASE	PHENOLIC (PF2736) 94V-0 10Φ (6P)	BAKELITE GESELLSCHAFT MBH	E61040(M)
4	WIRE	POLYURETHANE UEW 0.30Φ	TAIHAN ELECTRIC WIRE CO.,LTD. DONGSUH ELECTRONICS CO.,LTD.	E109312(N) E210918
5	FLUX	RF - 203 - H	DONG YUN KOREA CO.,LTD.	
6	SOLDER	SN98%,CU2%	ALPHA SOLDER CO.	



Na-3506, Chungang Circulation Complex, 1258
Kurobon-dong, Kuro-Ku, Seoul, Korea, 152-721
TEL: 02-2689-9418 , FAX: 02-2689-8628

DESIGN	CHECK	APPROVAL
<div style="border: 1px solid black; border-radius: 50%; padding: 5px; width: 60px; margin: 0 auto;"> 개발실 김영라 08.06.02 </div>	<div style="border: 1px solid black; border-radius: 50%; padding: 5px; width: 60px; margin: 0 auto;"> 개발실 이은숙 08.06.02 </div>	<div style="border: 1px solid black; border-radius: 50%; padding: 5px; width: 60px; margin: 0 auto;"> 개발실 조한석 08.06.02 </div>
FILE NO.	SH - 060601 - 01	

<h1 style="margin: 0;">SPECIFICATIONS</h1>	SHEET NO.	4 OF 7
	DATE	2008-06-02

PART NAME	LINE FILTER	MODEL NAME	
PART NO.	Φ10 x 2mH(H.B)	TYPE	T1004 (HM3A)

7. UL LIST

BAKELITE GESELLSCHAFT MBH. E 61040 (M)
GENNAER STRASSE 2-4 D-5860, ISERLOHN-LETMARHE
FED REP GERMANY

	Mtl Dsg	Col	Min ThK mm	UL94 Flame Class	Elec	RTI		H D				
						Mech with Imp	w/o Imp	H	V	4	C	
								H	H	V	4	C
								W	A	T	9	T
								I	I	R	5	I
Phenolic molding compound(PF), designated "Rutaform" or "Bakelite", furnished in the form of pellets or power.												
PF2736	BK		0.81	94V-0	150	150	150	-				
			1.57	94V-0	150	150	150	0	2	0	-	-
			3.07	94V-0	150	150	150	0	2	0	5	3
			3.07	94V-0	150	150	150	0	2	0	5	3

TAIHAN ELECTRIC WIRE CO., LTD. E 109312 (N)
194-15 1-KA HOEHYUN-DONG CHUNG-KU CPO
BOX 2624, SEOUL KOREA

Mtl Dsg	Coat type	Overcoat	ANSI Type	T1
Magnet wire.				
EI-AIW	Ester-imide imide	Polyamide-imide	MW35.73	200
AL EI-AIW	Ester-imide	Polyamide-imide	MW35	240
EIW	Ester-imide	-	MW30.72	180
EIW-N	Ester-imide	Polyamide	MW76	180
AIW	Polyamide-imide	-	-	220
PEW-N	Polyester	Polyamide	MW76	180
SEIW	Solderable Polyester-imide	-	MW77	180
UEW	Polyurethane	-	MW75	130
UEW-N	Polyurethane	Polyamide	MW80	155

Reports : April 2, 1987; April 2, 1987; April 2, 1987; April 2, 1987: April 2, 1987; April 2, 1987' April 2, 1987; April 2, 1987; April 2, 1987.

<p>NAMSUN ELECTRONICS CO., LTD. Na-3506, Chungang Circulation Complex, 1258 Kurobon-dong, Kuro-Ku, Seoul, Korea, 152-721 TEL: 02-2689-9418 , FAX: 02-2689-8628</p>	DESIGN	CHECK	APPROVAL
	08.06.02	08.06.02	08.06.02
	FILE NO.		SH - 060601 - 01

<h1 style="margin: 0;">SPECIFICATIONS</h1>	SHEET NO.	5 OF 7
	DATE	2008-06-02

PART NAME	LINE FILTER	MODEL NAME	
PART NO.	Φ10 x 2mH(H.B)	TYPE	T1004 (HM3A)

UL LIST

DONG SUH ELECTRONICS CO., LTD **E 210918**
 55-1 BUNSU 3-RI KWANGTAN-MYUN PAJU KYONGGI-DO
 413-850, KOREA

Mtl	Mark	Coat type		ANSI	
Dsg	Dsg	BC	Overcoat	Typ(+)	T1
DSUEW-100	(1)	Polyurethane	-	MW75C	130
UEW	(1)	polyurethane	None	MW79	155
				MW75	130(2)
PEW	(1)	Polyester	None	MW30	180
				MW5	155(2)

- (1) Marked designations are the same as the material designations.
- (2) Additional consideration is needed before its use in System's thermal aging.

Marking : Company name, material designation or marked designation on package or reel, and Recognized Component Mark.

<p>NAMSUN ELECTRONICS CO., LTD. Na-3506, Chungang Circulation Complex, 1258 Kurobon-dong, Kuro-Ku, Seoul, Korea, 152-721 TEL: 02-2689-9418 , FAX: 02-2689-8628</p>	DESIGN	CHECK	APPROVAL
	FILE NO.	SH - 060601 - 01	

<h1 style="margin: 0;">SPECIFICATIONS</h1>	SHEET NO.	6 OF 7
	DATE	2008-06-02

PART NAME	LINE FILTER	MODEL NAME	
PART NO.	Φ10 x 2mH(H.B)	TYPE	T1004 (HM3A)

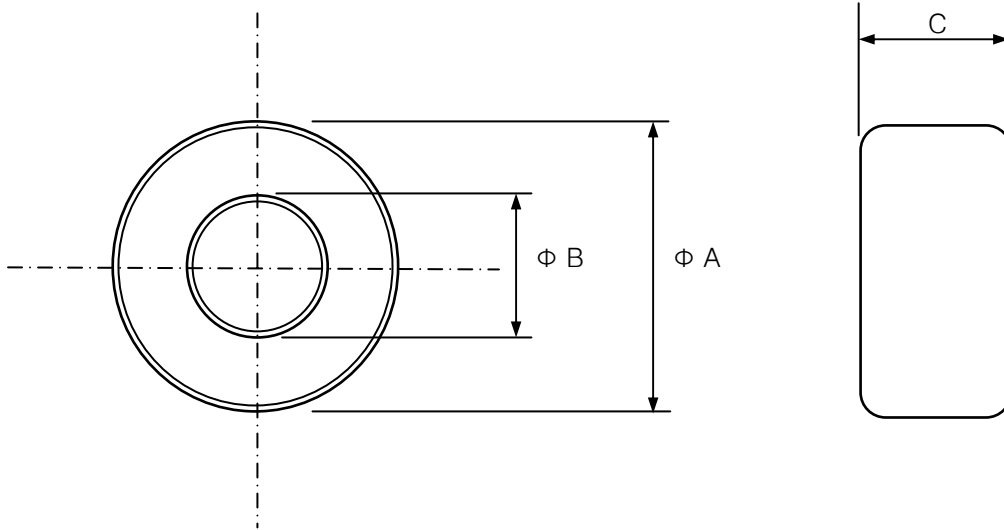

※ DIMENSION ※



구 분	DIMENSION (mm)			REMARK
	A	B	C	
T1004 (HM3A)	10.0 ±0.30	6.0 ±0.30	4.0 ±0.30	I SU

NAMSUN ELECTRONICS CO., LTD.

Na-3506, Chungang Circulation Complex, 1258
Kurobon-dong, Kuro-Ku, Seoul, Korea, 152-721
TEL: 02-2689-9418 , FAX: 02-2689-8628

DESIGN	CHECK	APPROVAL
		
FILE NO.	SH - 060601 - 01	

<h1>SPECIFICATIONS</h1>		SHEET NO.	7 OF 7
		DATE	2008-06-02
PART NAME	LINE FILTER	MODEL NAME	
PART NO.	Φ10 x 2mH(H.B)	TYPE	T1004 (HM3A)

※ LABEL SPECIFICATIONS (UNIT:mm) ※

DESCRIPTION	LINE FILTER	40
CODE NO	Φ10 x 2mH(H.B)	
SPECIFICATION	T1004	
QUANTITY	500PCS	
DATE OF MANUFACTURE		
TERM OF STORAGE	2008-06-02	
MANUFACTURER	NAMSUN ELECTRONICS CO.,LTD.	
50		
120		

※ BOX SPECIFICATIONS(UNIT:mm) ※

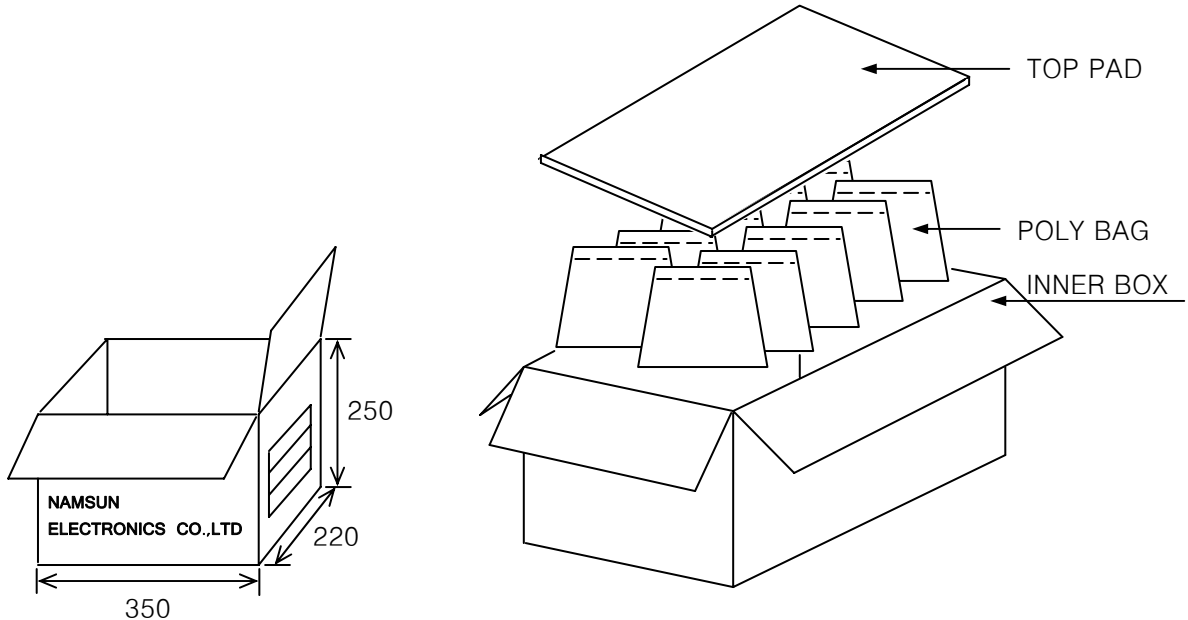

NAMSUN ELECTRONICS CO., LTD.

Na-3506, Chungang Circulation Complex, 1258
 Kurobon-dong, Kuro-Ku, Seoul, Korea, 152-721
 TEL:02-2689-9418 , FAX:02-2689-8628

DESIGN	CHECK	APPROVAL
개발실 김영라 08.06.02	개발실 이은숙 08.06.02	개발실 조한석 08.06.02
FILE NO.	SH - 060601 - 01	